

Oxford® Classic Lifts

User Instruction Manual

Mini
Midi
Major
Maxi

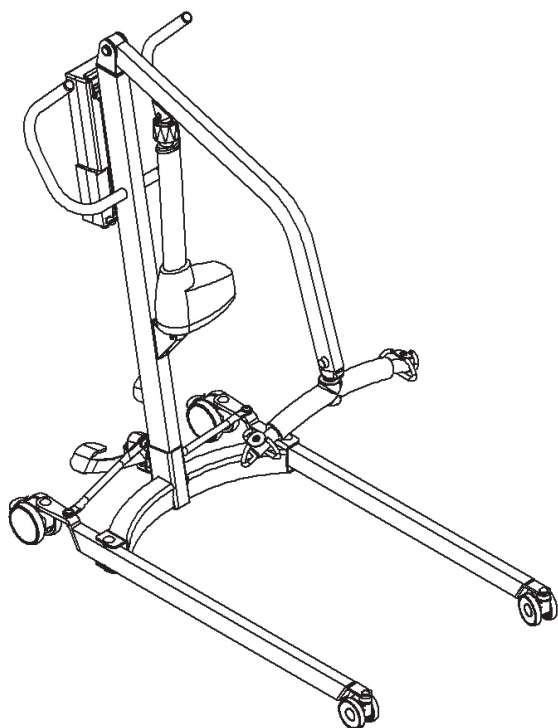

English

 **Joerns**
www.joerns.co.uk

Contents

1. Oxford Classic Lift Range	3
2. Introduction: About Your Lift	5
3. Assembly & Commissioning Instructions	6
4. Safety Precautions.....	9
5. Smart™ Monitor & Handset.....	11
7. Operating Instructions.....	15
8. Charging Instructions	18
9. Maintenance Schedule & Daily Check List.....	20
10. Technical Specifications	23
11. Warranty.....	28

1. Oxford Classic Lift Range

Oxford Mini 140:

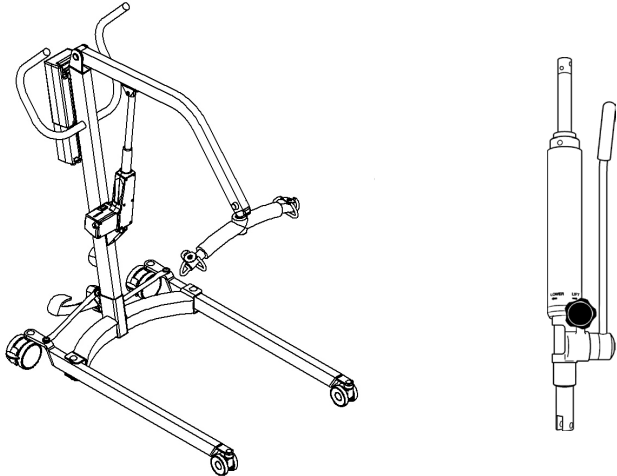

Fig. 1

Oxford Midi 180:

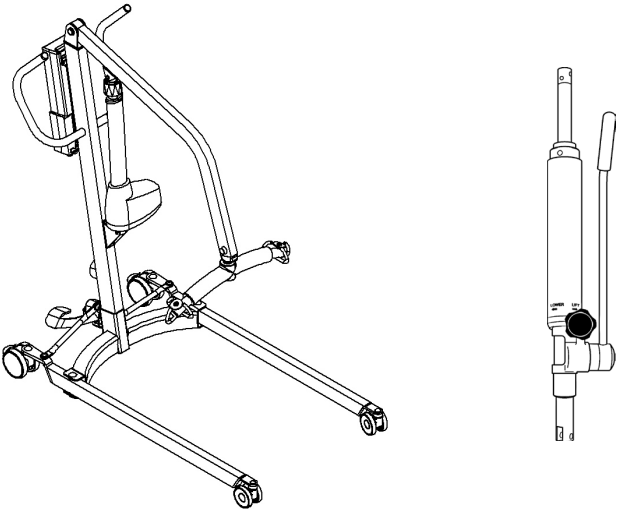

Fig. 2

Oxford Major 200:

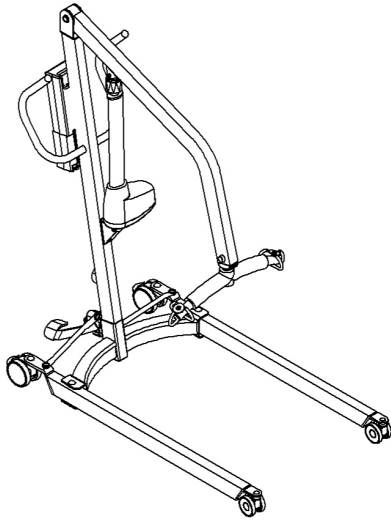

Fig. 3

Oxford Maxi 180:

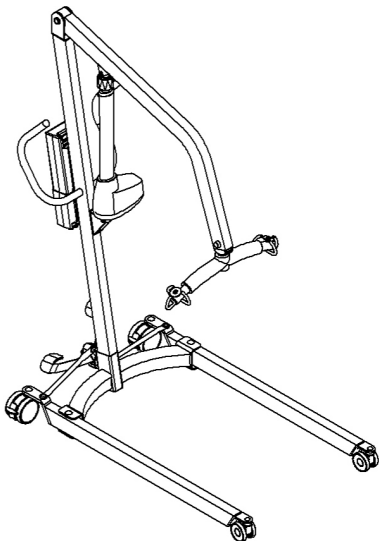

Fig. 4

2. Introduction: About Your Lift

The Oxford Classic Lift range is available with hydraulic or electric powered options with the exception of the Maxi 180 which is electric only. This manual covers both options.

Each lift is fully assembled, load tested and certified before being partially dismantled for packing. The packing consists of a strong, purpose built carton and is used for both export and domestic markets to ensure the safe arrival of the lift.

Recycling of Packaging:

In an effort to reduce levels of waste and environmental impact, Joerns Healthcare operate a free of charge recycling service in the UK. This is specifically for the foam inserts that accompany the lift packaging - inside of the carton.

When you are ready to return the foam inserts, simply present them to the Joerns Delivery Service Driver on their next visit and they will return them to us for recycling.

Accompanying Documents:

A number of documents are supplied in a wallet packed with each lift and should be retained for future reference.

- Test Certificate
- Dealer Guarantee Card
- User Manual

The TEST CERTIFICATE is an important document and is required for your insurance records. It is valid for 6 months and once expired, the lift should be inspected and serviced for the following six month period. Servicing and periodic LOLER testing can be carried out by your supplier. Please ensure your lift is included in their maintenance schedule.

The CE Mark:

Oxford Classic Lifts carry the CE mark and comply with the following EC directives:

- Medical Device Directive (93/42/EEC)
- EMC Directive (89/336/EEC) (Electrics only)
- Low Voltage Directive (73/23/EEC) (Electrics only)



Statement of Intended Use:

The intended use of this lifting device is to transfer an individual from one resting surface to another (such as a bed to a wheelchair). Moving a person in a sling over extended distances is not recommended. Oxford Classic Lifts are suitable for patients in the SITTING, SITTING/RECUMBENT and RECUMBENT positions.

Expected Service Life:

Oxford Classic mobile lifts are designed and tested for a minimum service life of seven (7) years, subject to the use and maintenance procedures stated in this manual. Use, other than in accordance with these instructions may compromise service life.

3. Assembly and Commissioning Instructions

Place the carton in a clear working area and open carefully. The carton contains:

- Main wheeled chassis
- Mast and boom assembly
- Battery pack
- Wallet containing documents
- Battery charger (electric lifts only)
- Hand control

1. Remove all the parts from the carton and place on the floor, taking care to protect the finish from damage.

⚠ WARNING

Some of the parts are heavy and will need to be lifted with care. You may need assistance with the heavier assemblies.

2. Apply the rear castor brakes by pushing the brake levers (Fig. 5) downwards.
3. Fit the mast assembly to the chassis. The mast is located into the rectangular socket on the top centre of the chassis. (Fig. 5).

⚠ WARNING

Avoid trapping fingers. Keep fingers away from the end of the mast when inserting into the socket.

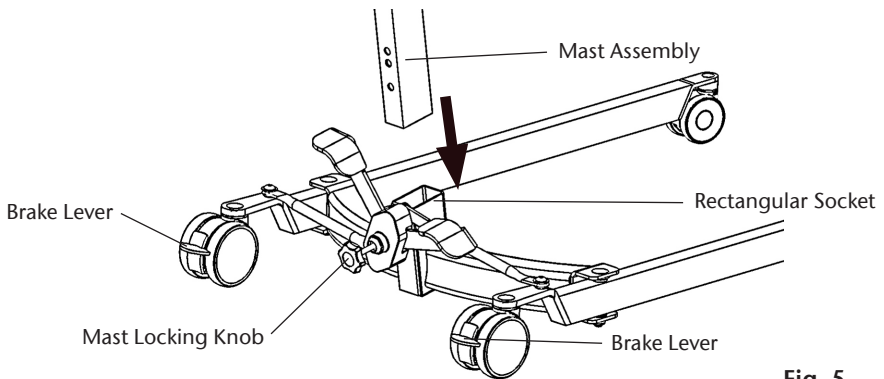

Fig. 5

4. When the mast is fully engaged within the socket, turn the mast locking knob (Fig. 5) clockwise, until fully tightened.

⚠ WARNING

Full engagement of the mast is indicated by the label on the side of the mast.

5. Release the brakes and confirm the legs of the lift open and close satisfactorily by operating the push pedals (Fig. 6) whilst holding onto the push handle for stability.

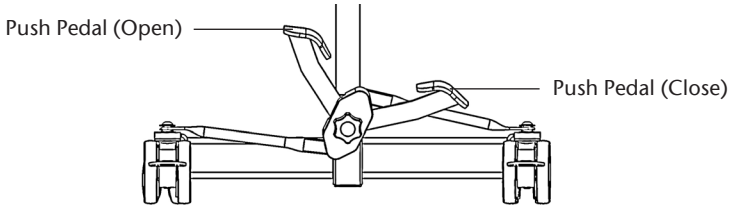

Fig. 6

Electric Models Only:

6. Clip the battery onto the control box and ensure the red emergency stop button, located on the controller is in the out (ON position) by turning clockwise (Fig. 7).

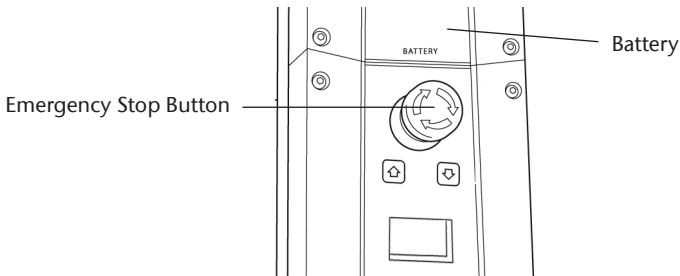

Fig. 7

7. Push the UP and DOWN buttons on the hand control and confirm the boom will raise and lower accordingly (Fig. 8).

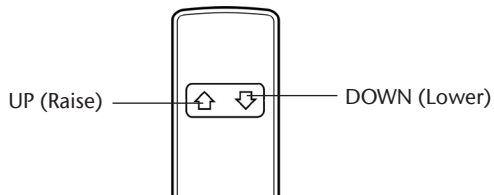
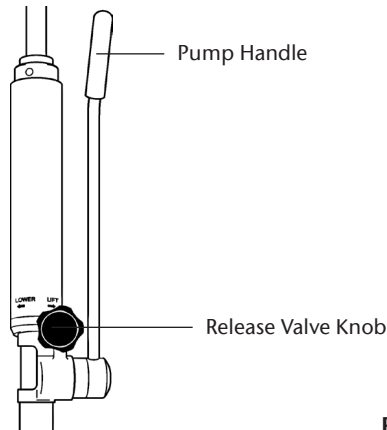

Fig. 8

8. The lift is now ready for use.

Hydraulic Models Only:

6. Close the hydraulic unit release valve (Fig. 9) by turning the knurled black knob on the unit fully clockwise.

**Fig. 9**

NOTE: The release valve requires only minimal tightening to operate and should only be closed finger tight.

⚠ WARNING

DO NOT apply excessive force to the release valve knob as this will result in damage to the valve.

7. Pump the handle (Fig. 9) of the hydraulic unit and confirm the ram raises the boom.
8. Open the release valve fully anti-clockwise and check the boom descends.

NOTE: An unloaded boom will not come down under its own weight, it will be necessary to apply some pressure to the boom before it will descend.

⚠ WARNING

The release valve is fully open and encounters a positive end stop in less than two full turns of the knob. DO NOT force the valve past the end stop as this will result in damage to the valve.

9. Close the release valve by turning the knurled black knob clockwise.
10. The lift is now ready for use.

4. Safety Precautions

Please read and follow the safety precautions listed below. The operation and use of Oxford patient lifts is simple and straightforward. Following these few basic safety precautions will make lifting operations easy and trouble free.

WARNING

- **ALWAYS** plan your lifting operations before commencing.
- **ALWAYS** carry out the **DAILY CHECK LIST** before using the lift.
- **ALWAYS** familiarise yourself with the operating control and safety features of a lift before lifting a patient.
- **DO NOT** use a sling unless it is recommended for use with the lift.
- **ALWAYS** check the sling is suitable for the particular patient and is of the correct size and capacity.
- **NEVER** use a sling which is frayed or damaged.
- **ALWAYS** fit the sling according to the instructions provided (user instructions).
- **ALWAYS** check the safe working load of the lift is suitable for the weight of the patient.
- **ALWAYS** carry out lifting according to the instructions in the user manual.
- **NEVER** disconnect or bypass a control or safety feature because it seems easier to operate the lift.
- **NEVER** force an operating or safety control. All controls are easy to use and do not require excessive force to operate. If a control is not working easily there will be a reason. Forcing will only strain or damage the lift and may compromise safety. If in doubt, contact your authorised Oxford Service Provider or Joerns Healthcare.
- **DO NOT** lift a patient with the castor brakes on.
- **DO NOT** attempt to manoeuvre the lift by pushing on the mast, boom or patient.
- **ALWAYS** manoeuvre the lift using the handles provided. **DO NOT** attempt to apply additional side force to the boom or legs of the lift in order to manoeuvre the product.
- **ALWAYS** lower the patient to the lowest comfortable position before transfers.
- **DO NOT** push a loaded lift at speeds which exceed a slow walking pace (3 kilometres/hour 0.8 metres/second).

- **DO NOT** push the lift over uneven or rough ground, particularly if loaded.
- **DO NOT** attempt to push or pull a loaded lift over a floor obstruction which the castors are unable to ride over easily.
- **DO NOT** bump the lift down steps, loaded or unloaded.
- **DO NOT** attempt to negotiate a loaded lift on a slope which exceeds 1:12 (approximately 5 degrees). Joerns Healthcare recommend a second helper is present when moving a patient on a slope.
- **DO NOT** park a loaded lift on ANY sloping surface.
- **DO NOT** use electric lifts in a shower.
- **DO NOT** charge an electric lift in a bathroom or shower room.
- **DO NOT** lift a patient unless you are trained and competent to do so.
- Your lift is for patient lifting. **DO NOT** use it, or allow it to be used, for any other purpose.

5. Smart Monitor & Handset

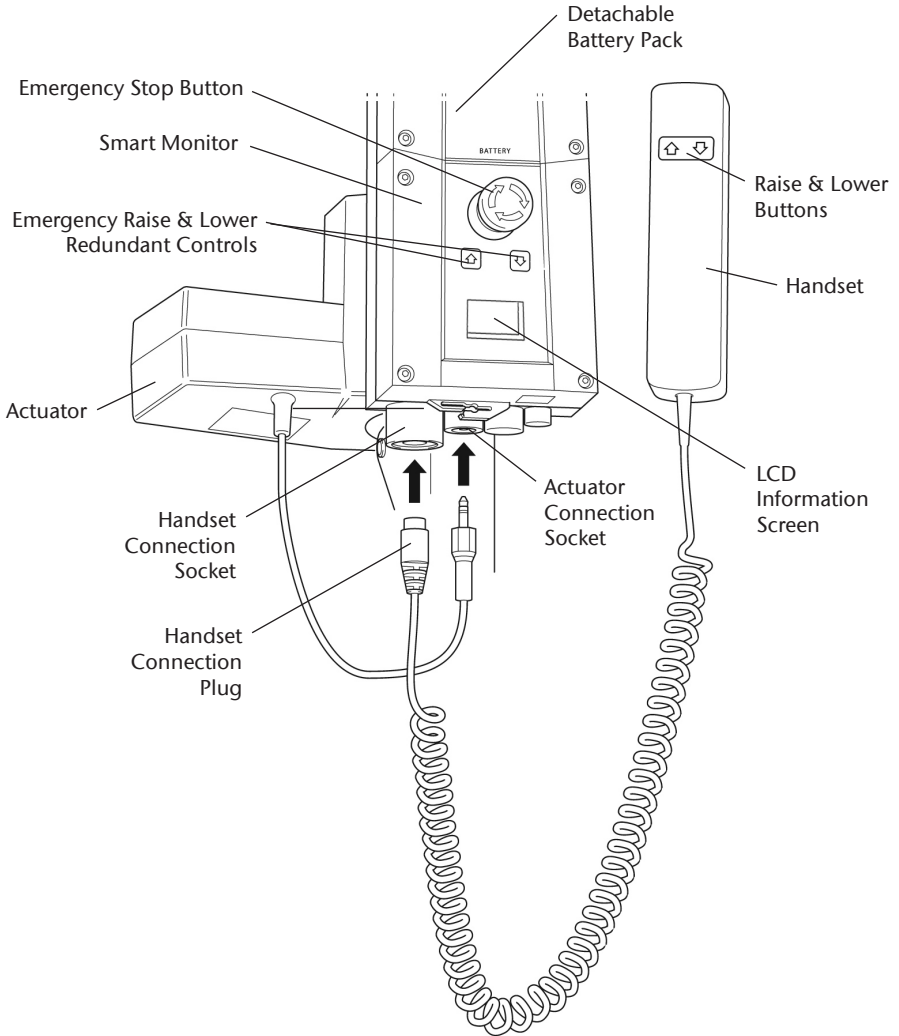

Fig. 10

Intended Use:

The Oxford Smart Monitor is a control system for Oxford Mobile Hoists. The Smart Monitor stores useful servicing information about the hoist that can be recalled when required. This servicing information includes:

- Number of patient lift cycles
- Total work done by actuator
- Number of lift overloads (attempted lifts above the safe working load)
- Number of days since last service interval

The Oxford Smart Monitor contains a microprocessor inside making it possible to read out service data via the on-board LCD screen.

Features:

- Data collection in the control box with data display via LCD screen
- Work counter
- Intelligent cycle counter
- Service indicator
- Service interval indicator
- Overload information
- 3 step battery indicator

Benefits:

- Improved safety for both patient and carer
- Accurate service data available at the touch of a button
- Optimised product life time
- Ease of maintenance for engineers and service technicians
- Fast and easy error identification

LCD Display Screen:

The Oxford Smart Monitor has the option to read out information via the LCD display screen. It is possible to read out total lifting cycles, total work done, overloads and number of days since last service, which can be used to quickly and easily evaluate the condition of the lift actuator (Fig. 11).

This information is accessed by a ½ second press on the 'UP' button on the User handset or redundant 'UP' button on the Smart Monitor.

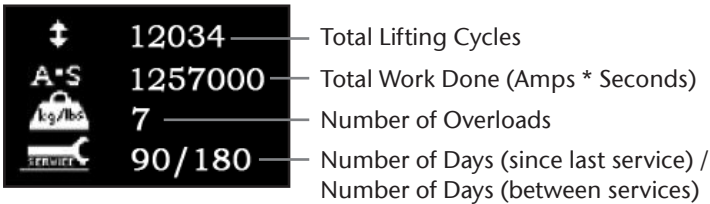

Fig. 11

Service & Usage Information:



Fig. 12

When it is time for a service, the service symbol will appear on the display (Fig. 12). In addition, when the user handset is activated, the Smart Monitor will give an audible signal giving notice to users that a service is required.

The service symbol will be displayed each time the raise or lower keys are depressed on the User handset. When the service symbol is displayed, contact your authorised service provider immediately to arrange a service.

You may continue to use your lift for a short period of time until a service has been carried out.



Fig. 13

If the lift stops because of an overload (an attempt to lift more than the safe working load) the overload symbol will appear on the LCD display (Fig. 13) and the lift will cease to operate until the additional load (above the SWL) has been removed.

WARNING

If the LCD display screen on your Smart Monitor has recorded an overload, Joerns Healthcare recommend that ALL routine daily checks are carried out on the lift prior to further use (for a list of daily checks, please refer to your lift user manual). Joerns Healthcare also recommend that you contact your authorised Oxford service provider for additional guidance.

On-Board Redundant Controls:

Fig. 14

On-board redundant controls enable the lift to be raised or lowered in the event of an emergency (Fig. 14).

Battery Information:

Fig. 15

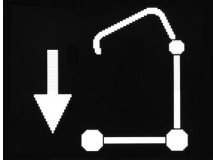
The display showing full battery means that the battery is fully charged and the lift is ready for use (Fig. 15).

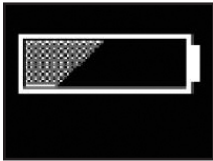

Fig. 16

The display showing a half empty battery indicates that it is time to charge the battery (Fig. 16).

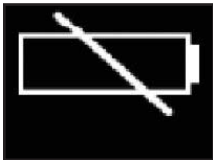

Fig. 17

The empty battery symbol showing on the display indicates that the battery has no capacity left and should be placed on charge immediately (Fig. 17).

⚠ WARNING

To avoid possible permanent damage to the battery, the battery should be placed on charge as soon as the display indicates the half empty battery symbol (Fig. 16).

7. Operating Instructions

1. **Leg adjustment:** The legs on the Classic Lifts are adjustable for width. The legs can be opened to enable access around armchairs or wheelchairs. For transferring and negotiating narrow doorways and passages, the lift legs should be in the closed position. To achieve the adjustment, simply operate the push-pads, located at the lower/rear of the mast. To open the legs, simply depress the LEFT push-pad, to close the legs, depress the RIGHT push-pad. The adjustment can be carried out with the patient in the lift.
2. **Castors and braking:** The lift has two braked castors which can be applied for parking. When lifting, the castors should be left free and unbraked. The lift will then be able to move to its centre of gravity. If the brakes are applied, it is the patient that will swing to the centre of gravity and this may prove disconcerting and uncomfortable.
3. **Direction of travel (Forward motion):** The Classic range of mobile lifts are designed to be pushed forwards using the integrated push-handle.

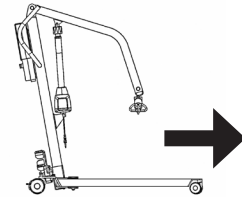

Fig. 18

4. **Straight line steering (where supplied):** One of the rear castors is fitted with a straight line steering device. To engage the device simply swing the 'U' shaped bar over the rear castor. The device will automatically engage as you move off.
5. **Raising and lowering the boom (electric models):** The movement of the boom is achieved by a powerful electric actuator which is controlled by a simple hand control unit. The hand control has two buttons with directional arrows UP and DOWN. The actuator stops automatically at the limit of travel in both directions. The hand control plugs into a socket at the base of the control box. There is a magnetic backing to the hand control which allows it to be "parked" on the mast or boom when not in use.
6. **Emergency stop (Electric only):** The red emergency stop button is located on the control box and is activated by pressing in. This will cut all power to the lift and can only be reset by twisting the button clockwise and releasing.
7. **Redundant controls:** All Oxford Classic Lifts are fitted with raise and lower buttons on the control box. These are located underneath the emergency stop button and can be used to lower/raise the patient should the hand control fail.

- 8. Emergency lower:** In the case of a complete electrical failure the electrical actuator is fitted with a spring loaded mechanical lowering device (RED BOSS). This will only operate when the lift is under load. The device must be twisted by hand and released to activate. A slow descent will commence. Repeat this process until the patient has been safely lowered.

⚠ WARNING

If this feature is used, the lift MUST be subsequently checked out by a competent engineer.

⚠ WARNING

Continued use of the hoist after using the emergency descent feature may compromise the duty of care and safety of the patient.

- 9. Batteries:** The batteries are protected from deep discharge by a LOW VOLTAGE ALARM. This will sound when the batteries need recharging and the hand control is being operated. It will not sound independently of the hand control being operated. **DO NOT IGNORE THIS WARNING ALARM.** Complete the lifting operation and place the lift on charge (see charging instructions).

- 10. Raising and lowering the boom (hydraulic models):** The raising and lowering of the boom is achieved by a powerful hydraulic ram which is operated by two simple controls. The release valve, which is identified by a black knurled knob, and the pump handle which is a long lever on the side of the hydraulic unit.

To raise the boom, ensure the release valve is closed. The valve is closed by gently turning the knurled knob fully clockwise. When closed, pump the long handle with smooth even strokes for maximum effect. The handle strokes from an upright position through an arc of 90 degrees. Leave the handle in the upright position when not in use.

⚠ WARNING

DO NOT force the handle beyond the upper or lower stops. The hydraulic unit can be rotated to allow the handle to be used from either side of the lift.

To lower the boom, turn the release valve anti-clockwise. The release valve is progressive, the more it is opened the faster the descent. The valve is restricted so even when fully open the descent is controlled. This facility allows for a “hands free” descent.

If the release valve is opened a fraction (a quarter turn) a very slow speed of descent will allow the carer to work “hands free” while assisting or comforting the patient.

REMEMBER to close the release valve before commencing lifting operations. The release valve only requires gentle pressure to open or close.

WARNING

DO NOT apply excessive force to the release valve, either to close or to open. It is not necessary and will only damage the valve.

11. **Slings:** The selected sling is attached to the spreader bar hooks. Each sling is supplied with instructions which should be followed carefully.

The Oxford Classic Lift range is suitable for patients in the SITTING, SITTING/RECUMBENT and RECUMBENT positions. The core slings suitable for these lifts are listed as follows:

- Oxford Quickfit
- Oxford Quickfit Deluxe
- Oxford Access
- Oxford Full Back
- Oxford Long Seat
- Oxford Silkfit

When selecting a sling from the Oxford range, be sure to assess the suitability of the type of sling for the patient to be lifted by conducting a thorough risk assessment prior to lifting.

NOTE: For detailed fitting instructions, please refer to the user guide supplied with each sling.

WARNING

Joerns Healthcare recommends that slings be checked regularly and particularly before each use for signs of fraying or damage. DO NOT use slings that are worn or damaged.

WARNING

OXFORD RECOMMENDS THE USE OF GENUINE OXFORD PARTS. Oxford sling and lift products are designed to be compatible with one another. For country specific guidance on sling use and compatibility, please refer to the sling label or contact your local market distributor or Joerns Healthcare.

WARNING

Refer to maximum weight capacity of lift. Sling capacity is limited by the maximum capacity of the lift.

NOTE: For further guidance on sling selection, please visit www.joerns.co.uk

8. Charging Instructions

The batteries are located in the power pack and are charged through two contacts on the base. When the power pack needs charging it is removed from the lift and fitted to a charging unit. Joerns Healthcare recommend an additional power pack is purchased, so that one pack can be on charge at all times.

1. Remove the power pack from the lift. The pack is retained by a simple latch at the top of the pack. Lift the latch and the power pack will be released.
2. Fit the power pack to the charging unit. The location and latching of the power pack to the charger is the same system as used on the lift.
3. Plug the charger mains plug into a suitable mains outlet and switch the mains supply ON.
4. Charging is automatic and will fully charge the batteries over a period of eight to twelve hours. **Note:** Even if the charger is left plugged in for extended periods it will not allow the batteries to “overcharge”.
 - a) Green Light - Indicates main power is on.
 - b) Yellow Light - Indicates battery is charging.
 - c) Battery will be fully charged when yellow light goes off.

Note: It is recommended that the battery be charged immediately upon receipt.

5. To return the lift to service, switch OFF the mains supply and remove the power pack from the charger. Fit the power pack to the lift and make sure the latch holding the pack in place is fully engaged.

The charging of Oxford electric lifts is simple and straightforward, but it is important to follow the charging instructions closely. Please pay particular attention to the following points, they will help you avoid problems with discharged batteries.

WARNING

To avoid possible permanent damage to the battery, the battery should be placed on charge as soon as the display indicates the half empty battery symbol (Fig. 16, page 14).

KEEP the batteries fully charged. Place the power pack on charge whenever it is not in use. If it is more convenient to do so, place on charge every night. The charger will not allow the batteries to “overcharge”.

⚠ WARNING

NEVER run the batteries completely flat. As soon as the audible warning sounds, complete the lifting operation in hand and place on charge.

NEVER store the power pack for long periods without regular charging throughout the storage period.

ALWAYS make sure the mains power to the charger is switched off before connecting or disconnecting the power pack.

NEVER leave the power pack plugged in to the charger with the mains power off.

ALWAYS check Battery Charge Indicator (LCD) screen.

Batteries NOT to be opened by unauthorised personnel. (Contact your distributor for warranty and repairs).

DO NOT touch battery/charger terminals.

DO NOT leave charger switched on with battery disconnected.

9. Maintenance Schedule and Daily Check List

All Oxford products are designed for minimum maintenance, however some safety checks and procedures are required. A schedule of DAILY tasks are detailed below.

Daily checks and a bi-annual service, inspection and test will ensure your lift is kept in optimum safe working condition. A list of spare parts is available upon request.

NOTE: The LOAD TEST and CERTIFICATION should only be carried out by qualified personnel or an authorised service dealer.

DAILY CHECK LIST:

Joerns Healthcare Ltd strongly recommend the following checks are carried out on a daily basis and before using the lift.

- **ENSURE** the lift moves freely on its castors.
- **ENSURE** the spreader bar is free to rotate and swing. Check the spreader bar is firmly attached to the boom.
- **EXAMINE** the sling hooks on the spreader bar and side suspenders for excessive wear. If in doubt - **DO NOT** use.
- **ENSURE** the sling retaining disks on the spreader bar are fitted and function as intended.
- **ENSURE** the legs open and close correctly.
- Operate the hand control or the hydraulic unit to **CONFIRM** the boom raises and lowers satisfactorily.
- **CONFIRM** the lift is not giving a low battery alarm when the hand control is operated (electric lifts only). If the alarm sounds, **DO NOT** use and place the battery on charge immediately.
- On electric powered lifts **CHECK** the operation of the emergency stop button.
- On hydraulically operated lifts **CHECK** for hydraulic fluid leakage. Any leakage should be reported to a service engineer immediately and the lift should not be used until it has been checked out.
- On lifts with detachable masts **MAKE SURE** the mast is fully engaged and the locking knob is fully tightened.
- **EXAMINE** slings for fraying or other damage. **DO NOT** use any sling if damaged or if the sling shows signs of wear.
- **EXAMINE** all fixings and fasteners and ensure they are secure prior to use.

MAINTENANCE, INSPECTION AND TEST:

Joerns Healthcare Ltd recommend a thorough inspection and test of the Oxford Mobile Hoist lifting accessories, slings etc. is carried out every six months. The examination and test should be conducted according to the recommendations and procedures below. Joerns Healthcare recommend maintenance, inspection and certified testing is carried out by authorised service dealers only.

NOTE: These recommendations are in compliance with the requirements of 1998 No. 2307 Health and Safety: The Lifting Operations and Lifting Equipment Regulations 1998. This is a UK regulation. Outside the UK please check your local requirements.

- **SPREADER BAR:** Check the spreader bar for freedom of rotation and swing. Check for wear on the central pivot. Check for firm attachment to the boom. Inspect for excessive wear on the sling hooks and any side suspenders used in conjunction with the spreader bar. Check that the sling retaining disks are fitted and function as intended.
- **BOOM:** Check for secure attachment of the boom to the mast. Make sure there is only minimal side movement of the boom and the boom is free to rotate on the boom bearing. Check that the actuator or hydraulic unit mounting on the boom is secure.
- **MAST:** Check the operation of the mast locking device. Make sure the mast fully engages into the socket. Check that the bottom actuator or hydraulic unit mounting is secure.
- **SMART MONITOR (Electric only):** Check the function of the emergency stop button. Inspect the hand control socket for correct fitting. Check functioning of the hand control. Check the redundant controls and confirm they operate as intended.
- **LEG ADJUSTMENT:** Check the leg linkages are secure. Operate the leg adjustment pedals and confirm smooth opening and closing of the legs. Adjust linkages if necessary.
- **LEG PIVOTS:** Check the leg pivots are secure and the legs pivot freely. Any stiffness must be investigated. Strip out the leg pivots and lubricate with a light mineral based grease if in any doubt. Make sure there is no excessive play in the leg pivots.
- **CASTORS:** Check all castors for firm attachment to the legs. Check for free rotation of the castor and the wheels. Remove any build up of threads, hair or fluff. Lubricate if necessary with a light mineral based grease. Check correct operation of the brakes.
- **ACTUATOR (Electric only):** The actuator should require no maintenance other than checking for correct operation and listening for unusual noise. Ensure all fixing points are secure. If in doubt, DO NOT use and have the unit checked by a qualified person or authorised Oxford Service Provider.

- **EMERGENCY RAISE/LOWER AND EMERGENCY DESCENT:** Check both the electrical emergency raise/lower and the emergency mechanical descent function using the maximum safe working load applied to the end of the boom. Please note that the practice of using a spring balance will not correctly check the function of the emergency descent function.
- **HYDRAULIC UNIT:** The hydraulic unit should require no maintenance other than checking for correct operation and leakage of hydraulic fluid.
- **BATTERIES (Electric only):** The batteries are located in the Power Pack and should not require maintenance other than the regular charging as detailed in the charging instructions.
- **CLEANING:** Clean with ordinary soap and water and/or any hard surface disinfectant. Harsh chemical cleaners or abrasives should be avoided as these may damage the surface finish of the lift. Avoid wetting any of the electrical parts.
- **SLINGS:** Check for wear and fraying. DO NOT use any sling that is damaged, or if the sling shows signs of wear.
- **LOAD TEST:** The load test should be carried out in accordance with the manufacturer's test procedures. It is strongly recommended the testing is carried out by an authorised service dealer.
- **CERTIFICATION:** An authorised service dealer will issue a test certificate after satisfactory completion of the load test. This certificate will be valid for six months.

10. Technical Specifications

The drawings below highlight key dimensions for the Oxford Classic range of lifts. Physical measurements for each lift are referenced over leaf.

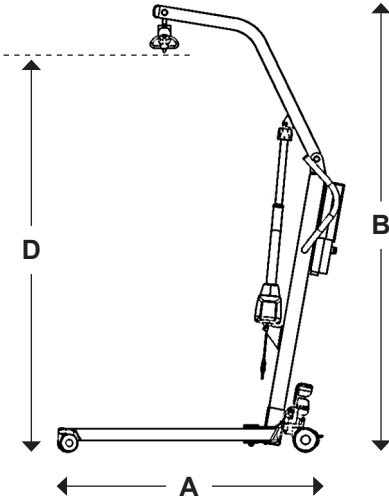

Fig. 19

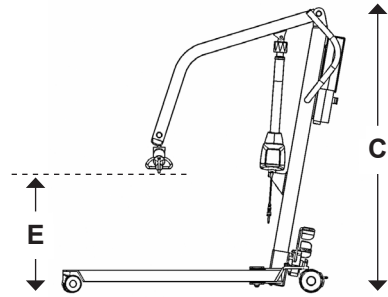

Fig. 20

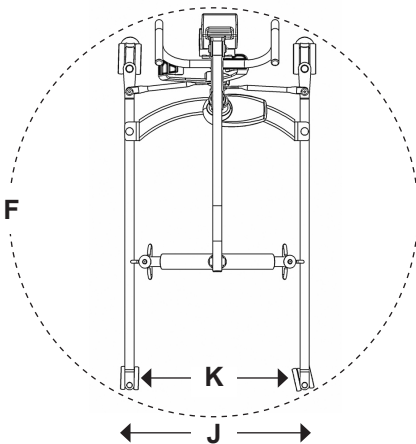

Fig. 21

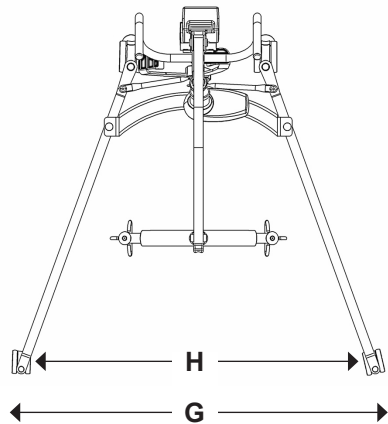

Fig. 22

MINI 140

	Electric	Hydraulic
Safe Working Load	140 kgs	140 kgs
Length (A)	1175 mm	1175 mm
Maximum Overall Height (B)	1730 mm	1730 mm
Minimum Overall Height (C)	1230 mm	1230 mm
Spreader Bar Max. Height (D)	1545 mm	1545 mm
Spreader Bar Min. Height (E)	530 mm	530 mm
Spreader Bar Height at Maximum Reach	1000 mm	1000 mm
Reach at Maximum Height *	400 mm	400 mm
Reach at Minimum Height *	400 mm	400 mm
Maximum Reach	565 mm	565 mm
Turning Radius (F)	1150 mm	1150 mm
Legs Open (External Width) (G)	1060 mm	1060 mm
(Internal Width) (H)	1000 mm	1000 mm
Legs Closed (External Width) (J)	600 mm	600 mm
(Internal Width) (K)	540 mm	540 mm
Overall Height of Legs	100 mm	100 mm
Ground Clearance	25 mm	25 mm
Front Twin Castors	75 mm	75 mm
Rear Braked Castors	100 mm	100 mm

Weights:

Mast & Boom Inc. all fixings	17.5 kgs	17.5 kgs
Base Assembly	11 kgs	11 kgs
Assembled Unit	28.5 kgs	28.5 kgs
Battery	2.9 kgs	-

* Reach = Centre of spreader bar to front of mast

MIDI 180		MAJOR 200		MAXI 180
Electric	Hydraulic	Electric	Hydraulic	Electric
180 kgs	180 kgs	200 kgs	200 kgs	180 kgs
1225 mm	1225 mm	1300 mm	1300 mm	1315 mm
1840 mm	1840 mm	1930 mm	1930 mm	2150 mm
1240 mm	1240 mm	1380 mm	1380 mm	1560 mm
1660 mm	1660 mm	1725 mm	1725 mm	1970 mm
525 mm	525 mm	525 mm	525 mm	780 mm
1060 mm	1060 mm	1200 mm	1200 mm	1420 mm
420 mm	420 mm	630 mm	630 mm	550 mm
440 mm	440 mm	490 mm	490 mm	540 mm
656 mm	656 mm	720 mm	720 mm	730 mm
1235 mm	1235 mm	1310 mm	1310 mm	1310 mm
1170 mm	1170 mm	1230 mm	1230 mm	1230 mm
1070 mm	1070 mm	1140 mm	1140 mm	1140 mm
600 mm	600 mm	660 mm	660 mm	660 mm
540 mm	540 mm	580 mm	580 mm	580 mm
100 mm	100 mm	100 mm	100 mm	100 mm
25 mm	25 mm	15 mm	15 mm	15 mm
75 mm	75 mm	75 mm	75 mm	75 mm
100 mm	100 mm	100 mm	100 mm	100 mm
20.5 kgs	20.5 kgs	23 kgs	23 kgs	24 kgs
11.5 kgs	11.5 kgs	19 kgs	19 kgs	19 kgs
32 kgs	32 kgs	42 kgs	42 kgs	43 kgs
2.9 kgs	-	2.9 kgs	-	2.9 kgs

Electrical Specifications:

Batteries	2 x 12 Volt rechargeable sealed lead acid type
Battery Capacity	2.9 Ampere hours
Charger Rated Input	100-240V AC/24 VDC 50/60 Hz. Max 400MA
Charger Rated Output	29.5 VDC. Max 19W

Electric Shock Protection:

Charger	Class II
Lift.....	Internal Power Source

Degree of Shock Protection:

Charger	Type B
Lift.....	Type B

Environmental Conditions:

Outside this environment functionality and safety may be compromised.

Operating:

Temperature	5°C to 40°C
Relative humidity.....	20% to 90% @ 30°C - not condensing
Atmospheric pressure.....	700 to 1060 hPa
Noise level.....	55 dB

Storage:

Temperature	-10°C to +50°C
Relative humidity.....	20% to 90% @ 30°C - not condensing
Atmospheric pressure.....	700 to 1060 hPa

IP Ratings:

Control Box	IPX4
Actuator	IPX4
Off Board Charger	IPX5
Battery	IPX5
Handset	IPX5

Duty Cycles:

Actuator	10% (2 min/18 min)
Battery	10% (2 min/18 min)

Key Symbols:

The following symbols are used on the charger, control unit and battery:



Type B equipment, as per EN 60601-1



Class 2 equipment



The disposal of electrical components should not be mixed with general household waste



For indoor use



ATTENTION, consult accompanying documents.

WEEE Producers registration number WEE/GG0464RZ

11. Servicing, Repairs, Inspections and Testing

Joerns Healthcare has an established network of reputable distributors and dealers who will be pleased to handle all your purchasing, warranty, repair and maintenance enquires.

This product is guaranteed for a period of twelve months from the date of manufacture or twelve months from the date of purchase if commissioned by an authorised dealer. We recommend that all of our products are commissioned by your dealer and are supported by them for future servicing.

The dealer or distributor operates the warranty programme, so it is important to keep a record of their name address and telephone number so they can be contacted should any problem arise.

If you are in doubt as to where your product was purchased, Joerns Healthcare can trace the supplier if you quote the serial number of the lift. Contact details can be found on the rear cover of this manual.

REMEMBER: Contact your distributor for purchases, warranty, repairs, servicing and certified maintenance.

Your distributor:

Packing Check List:

- | | |
|--|--|
| <input type="checkbox"/> User Manual | <input type="checkbox"/> Charger with Stand & Lead |
| <input type="checkbox"/> Test Certificate | <input type="checkbox"/> Base Assembly |
| <input type="checkbox"/> Dealer Guarantee Card | <input type="checkbox"/> Mast & Boom Assembly |
| <input type="checkbox"/> User Handset | <input type="checkbox"/> Foam Packaging Inserts |
| <input type="checkbox"/> Battery Pack | <input type="checkbox"/> _____ |

Checked for you by: _____



Joerns Healthcare Ltd

Drakes Broughton Business Park
Worcester Road, Drakes Broughton
Pershore, Worcestershire
WR10 2AG, United Kingdom
(P) +44 (0)844 811 1156
(F) +44 (0)844 811 1157
info@joerns.co.uk