

JAZZY CARBON ULTRA-LITE POWER CHAIR



Formatted: Centred

[include pg numbers]

TABLE OF CONTENTS

1. LETTER TO USERS
2. ATTENTION
3. PRODUCT DESCRIPTION
4. INSTALLATION & ADJUSTMENT
5. OPERATING INSTRUCTIONS
6. BATTERY AND CHARGER
7. DAILY CHECKS & MAINTENANCE [fix section header]
8. WARRANTY
9. BASIC TROUBLESHOOTING
10. TRANSPORTATION AND STORAGE

Deleted: CHECKING

1. LETTER TO USERS

This product is designed and produced by Kunshan Hi-Fortune Health Products Co., Ltd on behalf of Pride Mobility Products UK, Ltd.

This Owner's Manual is part of the product specifications; please ensure it accompanies every product sold and it is read thoroughly and understood before operating or driving the powerchair.

This Owner's Manual is compiled from the latest specifications and product information available at the time of publication. We reserve the right to make changes as they become necessary. Any changes to our products may cause slight variations between the illustrations and explanations in the Owner's Manual and the product you have purchased.

NOTE: This product and its components are not made with natural rubber latex. Consult with the manufacturer regarding after-market accessories.

Please keep the following information:

Production information
(paste the barcode)

Deleted: ,

Deleted: -

Deleted: any

Deleted: s

2.ATTENTION

2.1 UNPACKING INSPECTION

Please use the Parts List provided to check whether any parts or components are damaged or missing. If there is any damage or missing parts, contact your dealer or distributor immediately.

- Powerchair 1
- Cushion 1 set
- Charger 1
- User Manual

Deleted: the powerchair and









Deleted: (according to the Parts List provided with the product)...

Deleted: please

Deleted: the

Deleted: or the company in time

2.2 EXPLANATION OF SYMBOLS

Symbols	Description	Note
 WARNING	Hazard identification to cause either personal death or injury.	
 CAUTION	Failure to follow designated procedures can cause either personal injury, Component damage, or malfunction.	
	Mandatory	
	Prohibited	
	Refer to instruction manual/ booklet	
	Warning: hands/fingers pinch exist	
	Type B IEC 60601-1	
	Class II IEC 60601-1	

2.3 SAFETY INSTRUCTIONS

- ⚠ Read this Owner's Manual carefully before using your powerchair and make sure that you understand the use and operating details of all the various components, they are present.

Deleted: these parts and

WARNING:

- ⊘ Do not drive on roads with heavy traffic or roads that are muddy, gravelly, bumpy, narrow, covered with snow, of ice, canal towpaths not guarded by any fence or hedge barrier. High levels of humidity or very cold conditions can reduce the performance of your power chair.
- ⊘ Never attempt to physically modify a power chair including the addition of third-party componentry as changes to power chairs will render your warranty void and that are likely to affect conformance and risk evaluation.
- ⊘ Do not suddenly shift of your body gravity as this could make the powerchair unstable.
- ⚠ Lean forward when climbing, and lean back when going downhill, turn the speed control dial to low. Do not drive across a slope at an angle – always drive straight up and down the slope.

Deleted: ed over,

Deleted: icy

Deleted: or

2 ATTENTION

Note:

- ⓘ When using your power chair on streets or footpaths, local laws and regulations apply.

GENERAL SAFETY–WARNINGS FOR SAFE USE

- ⓘ **MANDATORY !** This complete user's manual should be read and fully understood before using and driving the powerchair.
- ⚠ **WARNING!** Disobeying the instructions described in this manual may result in damage to the power- chair or body injuries to the user.
- ⓘ Neither should it be used by people obviously suffering from physical or mental limitations that render them incapable of safely handling the power chair in traffic.
- ⚠ **WARNING!** Never exceed the maximum permissible load – see Specifications.
- ⊘ **WARNING!** Never drive the powerchair under the influence of medication or alcohol.
- ⚠ If you are taking medication check with your doctor or physician that your ability to control the power chair will not be impaired.
- ⚠ Inspect all electrical connections, all controller connections, the brakes and battery charge to know the feel of your power chair and its capabilities as Pre-Ride Safety Check.
- ⊘ Designed solely for ~~single use; no riders or additional persons.~~
- ⚠ **WARNING!** Never attempt to get onto or off your powerchair without first turning off the Joystick controller. This will prevent the powerchair from moving if accidental Joystick control contact is made.
- ⚠ **WARNING!** Never descend or climb a gradient which is greater than the recommended maximum see (3.4) Specifications.
- ⊘ **WARNING!** Never drive across (traverse) an incline, ramp etc., in any direction.
- ⚠ **WARNING!** Never use the powerchair without the anti-tip wheels correctly fitted.
- ⊘ **WARNING!** Do not use your powerchair on sand, rough terrain, or wet and slippery surfaces.

- ⚠ **WARNING!** This powerchair is not intended for use as a seat in a motor vehicle. The wheelchair could fail in a vehicle impact, leading to injury of the powerchair occupant or others.
- ⚠ **WARNING!** Do not use the powerchair if it is broken or is not functioning correctly.
- ⚠ **WARNING!** Before leaning or reaching forward, always push your bottom to the back of the chair and face the castors forwards.
- ⊘ **WARNING!** Never stand on the footplate, this will cause the powerchair to tip over and injure the user.
- ⚠ **WARNING!** Always place the powerchair on a stable, flat surface before transferring to or from the powerchair.
- ⚠ **WARNING!** The anti-tip wheels are only effective on firm ground. They will sink into soft ground such as grass, snow, or mud if the powerchair rests on them. On such surfaces, the anti-tip wheels will not function as intended and the powerchair could tip over. **WARNING!** Turning your powerchair too sharply at high speed will cause loss of control and balance and will result in the powerchair tipping over resulting in serious injury or death.

Deleted: which are

Deleted: use by

Deleted: disabled person,

Deleted: may be transferred along with it

Deleted:

Deleted: They will lose their effect

2 ATTENTION

2.4 INTENDED USE

This powerchair incorporates manufacturer's own designs and can be used in confined spaces both indoors and outdoors by the occupant and it is intended to comfortably transport adult people only excluding goods but user's weight should be limited to 125kg (275 lbs). Neither should it be used by people obviously suffering from physical or mental limitations that render them incapable of safely handling the powerchair in traffic.

Deleted: and dimensions

Deleted: in

Deleted: load- ing





2.5 REMARKS ON ELECTROMAGNETIC COMPATIBILITY (EMC)

We wish to point out that sources of electromagnetic waves (e.g. cell phones) are liable to create interference. The electronics of the power chair itself could affect other electric appliances as well.

Deleted: s

Deleted: too

To reduce the effect of electromagnetic sources of interference, please read the following warnings:

-  **WARNING:** The power chair might disturb the operation of devices in its environment that emit electromagnetic field.
-  **WARNING:** The driving performance of the power chair can be influenced by electromagnetic fields (e.g. electricity generators or high power sources).
-  **WARNING:** Avoid using any portable TV or radio in the immediate environment of your power chair for as long as it is turned on.
-  **WARNING:** Check the area for transmitter masts and avoid using the power chair close to them.
-  **WARNING:** If involuntary movements or braking occur, turn off the power chair as soon as it is safe to do so.

Interfering electromagnetic fields may have a negative effect on the power chair's electronic systems. These can include:

- Disengagement of the engine brake
- Uncontrollable behavior by the power chair

In the presence of very strong or enduring interfering fields, the electronic systems could even break down entirely or malfunction.

Deleted: suffer permanent damage

2 ATTENTION

POSSIBLE SOURCES OF RADIATION INCLUDE:

Portable receiver and transmitter installations (receiver and transmitter with fixed antenna mounted directly on the transmitting unit)

- Transmitting and receiving sets
- Cell phones or "walkie talkie"
- portable TV, radio and navigation devices
- other personal transmitting devices
- Mobile medium-range transmitting and receiving devices (e.g. car antennas, with the antenna mounted on the outside of the vehicle)
- Fixed transmitting and receiving sets
- Fixed mobile transmitting and receiving devices
- Fixed radio, TV and navigation systems
- Long-range transmitting and receiving devices
- Radio and television towers
- radio sets

Other home devices like CD player, notebook, cordless phones, AM/FM radios, electric shavers and hair dryers, so far as we know, will have no influence provided that they function perfectly and their cabling be in an excellent condition. Please conform to the operating instructions accompanying such electric instruments to ensure trouble free operating of your power chair.

Deleted: -

1. Do not operate hand-held (transceivers-receivers), such as citizens band (CB) radios, or turn ON personal communication devices, such as cellular phones, while the powered vehicle is turned ON;
2. Be aware of nearby transmitters, such as radio or TV stations, and try to avoid coming close to them;
3. If unintended movement or brake release occurs, turn the powered vehicle OFF as soon as it is safe;
4. Be aware that adding accessories or components, or modifying the powered vehicle, may make it more susceptible to EMI (Note: There is no easy way to evaluate their effect on the overall safe working of the powered vehicle);

Deleted: d

Deleted: immunity

3 PRODUCT DESCRIPTION

3.1-A PRODUCT FEATURES (HP200)

3.1.1 This product consists of frame, wheels, seat, armrest, lithium battery, motor and controller with a lightweight and compact design. The whole wheelchair can be folded by one button and it can be easily carried or rolled after folding. The armrest can be flipped backward, which is convenient for the elderly to move. It is also equipped with a high-performance controller, which can be flexibly operated by the elderly.

The battery box can be removed for charging.

3.1.2 IPX4 water resistance rating and anti-electric shock: Type B applied part

3.1.3 This product is designed for simplified operation and is user-friendly.

3.1.4 The ergonomic stretch mesh backrest and seat are designed to provide ample comfort for the driver.

3.1.5 This product is suitable for use indoors and on flat roads near buildings.



HP200
(All carbon z)

Deleted: .
Deleted: It has the
Deleted: pulled

3.2 MAIN STRUCTURE

3.2.1 PART NAMES

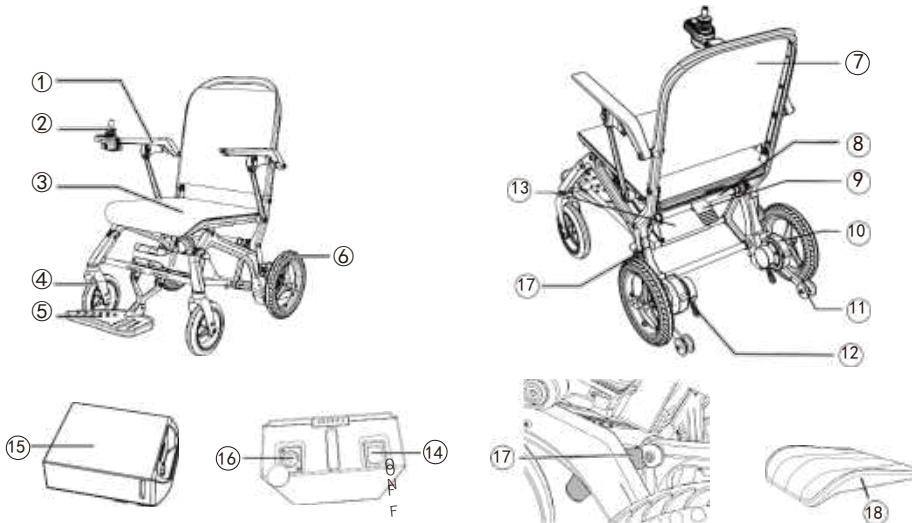

- | | | | |
|------------------------|-------------------------|---------------------|-------------------|
| 1. Armrest | 6. Rear wheel | 11. Anti-tip wheel | 16. Charging port |
| 2. Joystick | 7. Backrest | 12. Freewheel lever | 17. Lock piece |
| 3. Seat (Stretch mesh) | 8. Lock lever | 13. Battery box | 18. Cushion |
| 4. Front wheel | 9. Foldable lock handle | 14. Battery switch | |
| 5. Footrest | 10. Rear wheel assembly | 15. Battery | |

3 PRODUCT DESCRIPTION

3.1-B PRODUCT FEATURES (HP205)

- 3.1.1 This product consists of frame, wheels, seat, armrest, lithium battery, motor and controller. It has the lightweight and compact design. The wheelchair can be folded by one button and it can be easily pulled after folding. The armrest can be flipped backward, which is convenient for the elderly to move. It is also equipped with a high-performance controller, which can be flexibly operated by the elderly. The battery box can be removed for charging.
- 3.1.2 IPX4 water resistance rating and anti-electric shock:
Type B applied part
- 3.1.3 This product is designed for simplified operation and is user-friendly.
- 3.1.4 The ergonomic seat is designed to provide ample comfort for the driver.
- 3.1.5 This product is suitable for use indoors and on flat roads near buildings.



HP205
(Carbon fibre + aluminum alloy)

Deleted: whole

3.2 MAIN STRUCTURE

3.2.1 Part Names

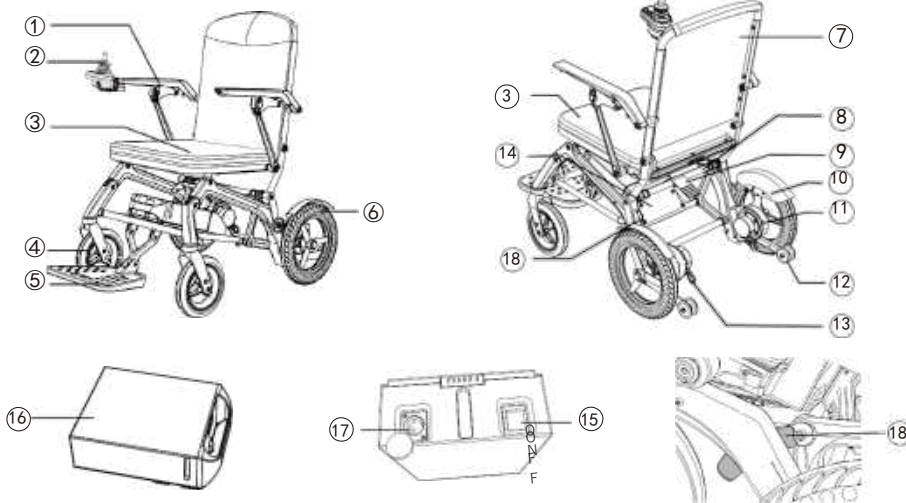

- | | | | |
|---------------------|-------------------------|-------------------------|-------------------|
| 1. Armrest | 6. Rear wheel | 11. Rear wheel assembly | 16. Battery |
| 2. Joystick | 7. Backrest | 12. Anti-tip wheel | 17. Charging port |
| 3. Seat and cushion | 8. Lock lever | 13. Freewheel lever | 18. Lock piece |
| 4. Front wheel | 9. Foldable lock handle | 14. Battery box | |
| 5. Footrest | 10. Rear mudguard | 15. Battery switch | |

3 PRODUCT DESCRIPTION

3.3 CIRCUIT DIAGRAM

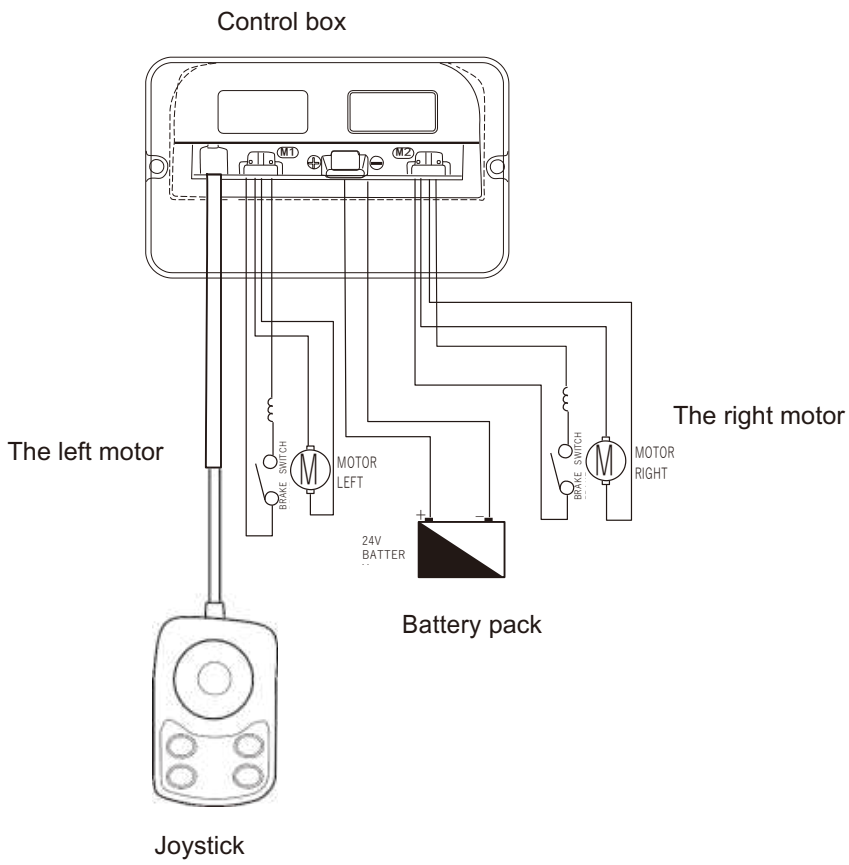

3 PRODUCT DESCRIPTION

3.4 TECHNICAL PARAMETERS

Technical models	HP200	HP205
Frame	Carbon fibre	(Carbon fibre + aluminum alloy)
Weight (W/T Battery)	14.5KG	16.5KG
Max. load	125kg	125kg
Motor (Rated output power)	24V 170W	24V 170W
Battery	24V 20Ah/10.4Ah Li-ion battery (optional)	24V 20Ah/10.4Ah Li-ion battery (optional)
Charger	29.4v 2A Microphone head, AC PLUG medium gauge	29.4v 2A Microphone head, AC PLUG medium gauge
Front wheel	8" PU tire	8" PU tire
Rear wheel	12" tires and carbon fibre rim	12" tires and magnesium fibre rim
Armrest	Flip up	Flip up
Footrest	Foldable	Foldable
Brake	Electromagnetic brake	Electromagnetic brake
Seat and backrest cushion	Stretch mesh	Oxford fabric + sponge cushion
Opened dimensions	1000x620x950 (mm)	1000x620x950 (mm)
Folded dimensions	620x340x800 (mm)	620x340x800 (mm)
Seat width	450 mm	450 mm
Seat depth	450 mm	450 mm
Seat height above ground	480 mm	480 mm
Armrest height	250 mm	250 mm
Backrest height	520 mm	520 mm
Max. speed	6.0KM/h	6.0KM/h
Static stability	≥9°	≥9°
Dynamic stability	≥6°	≥6°
Braking distance on horizontal road	≤1.1 m	≤1.1 m
Slope holding performance	9°	9°
Climbing ability	≥6°	≥6°
Obstacle crossing height	≥40 mm	≥40 mm
Ditch crossing width	100 mm	100 mm
Min. turning radius	≤900 mm	≤900 mm
Theoretical driving distance (20AH battery)	20 Km	20 Km

4.INSTALLATION & ADJUSTMENT

4.1 CONTROLLER INSTALLATION/REMOVAL

Insert the upper bracket of the joystick into the fixed tube of the armrest as shown in the diagram then tighten it with the knob. Operate oppositely if operated with left hand.

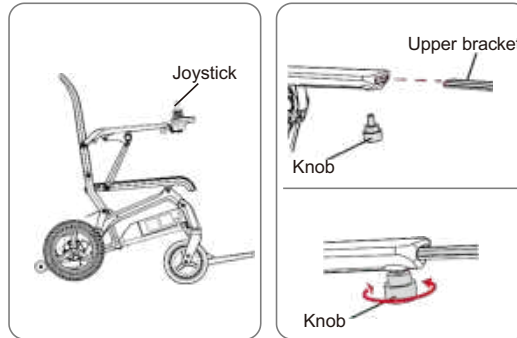



4.2 MANUAL FREEWHEEL LEVER

Pull the freewheel levers the open position  to put the wheelchair in the brake-release position and you can push the wheelchair manually. When the handle is pushed to the closed position, the wheelchair is in the braking state and cannot be pushed.

WARNING:

The brake must be in the closed state  i.e., the wheelchair can be started when it is in the braking state.

 It is forbidden to use the  opening function when the wheelchair goes uphill or downhill in order to ensure the safety of the user and wheelchair.

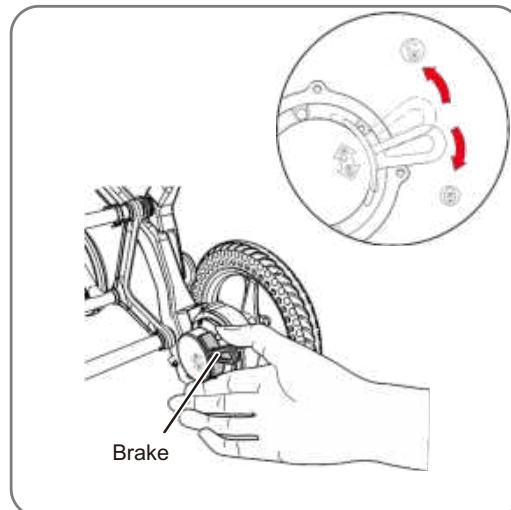

WARNING:

1. Turn off the power button on the controller before the brakes are closed and do not sit on the seat while the brakes are opened. Do not open the brakes when the wheelchair is on a slope or any sloped position.
2. The brake system is in the open state when the brake is opened.
3. When the brake is opened, the wheelchair can only be pushed on the horizontal surface. After that, please put the electromagnetic brake to the closed state.

4. INSTALLATION & ADJUSTMENT

4.3 BATTERY BOX INSTALLATION, REMOVAL OR REPLACEMENT

4.3.1 Installation: Push the battery box forward along the U-shaped fixing strip and align it with the front terminal until it clicks in place.

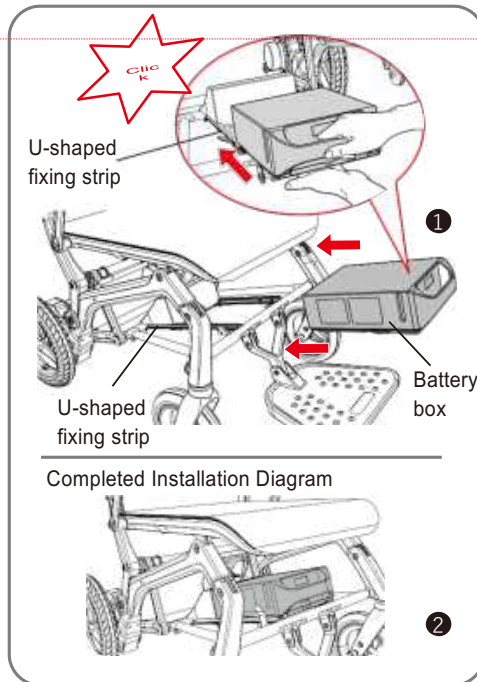

4.3.2 Removal or replacement: Remove the battery box by pressing the battery lock handle while pulling the battery box back along the slot.

Attention:

- ① When inserting the battery box, the button on the battery box should be in the "ON" state, i.e., the power is on.
- ② Hold the battery with both hands to prevent dropping when to install or remove the battery.

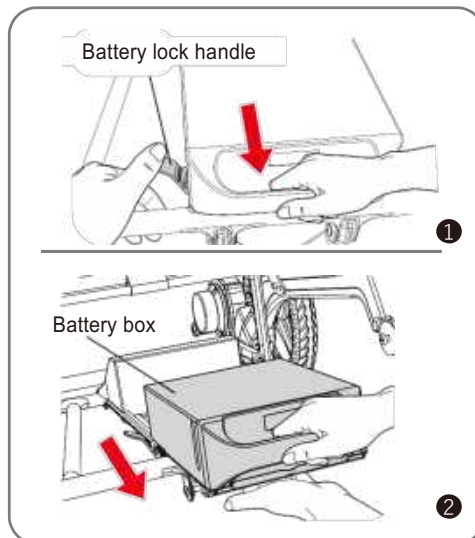

4. INSTALLATION & ADJUSTMENT

4.4 SEAT BELT REMOVAL AND INSTALLATION

1. Hold the buckle on the seat belt and press together to unbuckle the seat belt.
2. Align the buckle with the insert, press down until you hear the "click" sound.

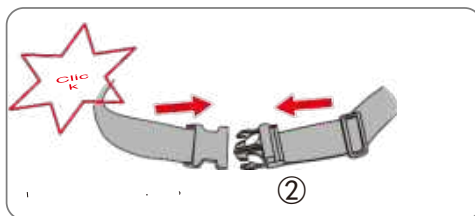
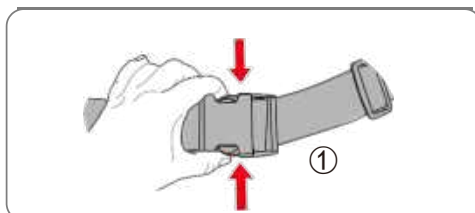

WARNING

Please fasten the seat belt when you sit in the wheelchair.

4.5 ANTI-TIP WHEEL

1. The wheelchair is equipped with anti-tip wheels, which are used to prevent the wheelchair from tipping over in an emergency. The anti-tip wheels of this wheelchair cannot be removed.

WARNING

Do not drive the wheelchair if the anti-tip wheels are removed or damaged.

WARNING

Anti-tip wheels are only suitable for hard surfaces. If the road is muddy, the anti-tip wheel may get stuck.

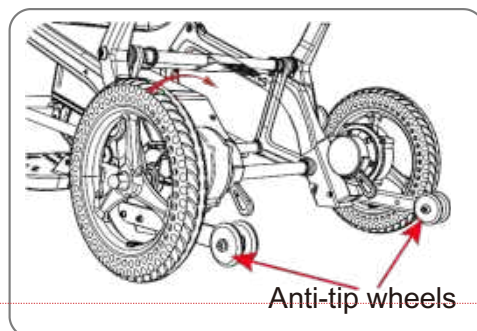

Deleted: after

4.5.1 ARMREST LIFTING

- ① Press the red button on the side.
- ② The armrest can be lifted up or down, making it easy to get in or out of the wheelchair.

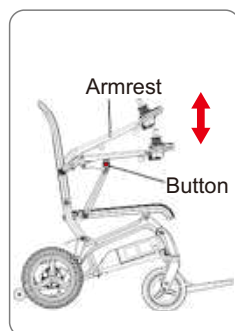

4.INSTALLATION & ADJUSTMENT

4.6 UNFOLDING THE POWERCHAIR

4.6.1 Hold the backrest frame with your left hand and open the footrest with your right hand as shown in the right diagram.

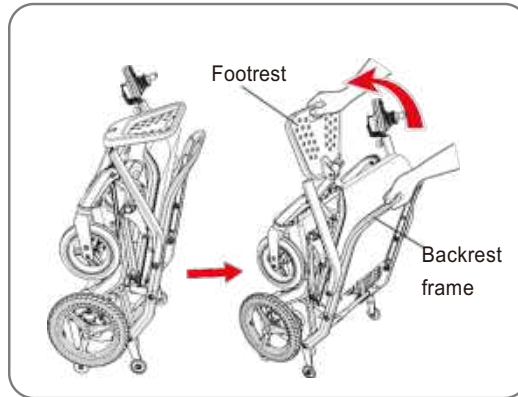

4.6.2 Before opening the powerchair, place the whole vehicle flat;

- ① Press the lock piece with the right hand to stagger the screw and the lock piece.
- ② At the same time, hold the backrest frame with your left hand and lift it upward to unfold outwards.

After the screw is separated from the lock piece, you can release it with your right hand.

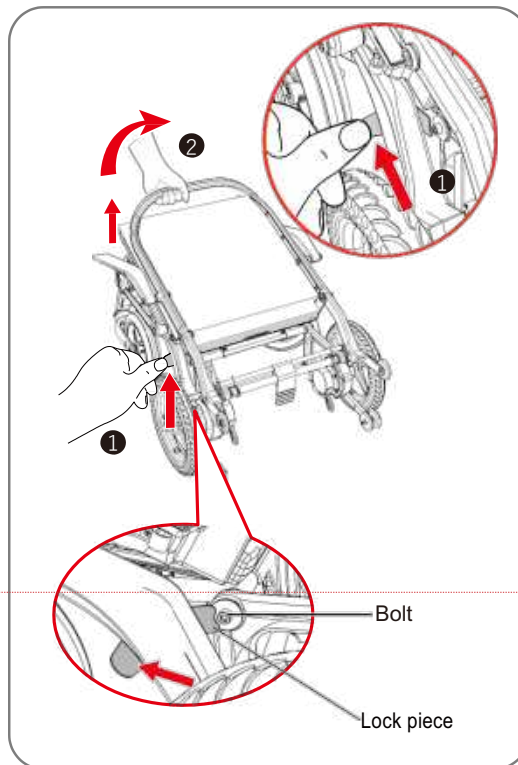

Attention:

When performing step ②, release your hand that pulls the release rope in time to prevent hand pinching!

Deleted:

4.INSTALLATION & ADJUSTMENT

4.6.3 When the backrest frame is opened, the wheelchair is fully opened when you hear the "click" sound and the hook snaps in place.

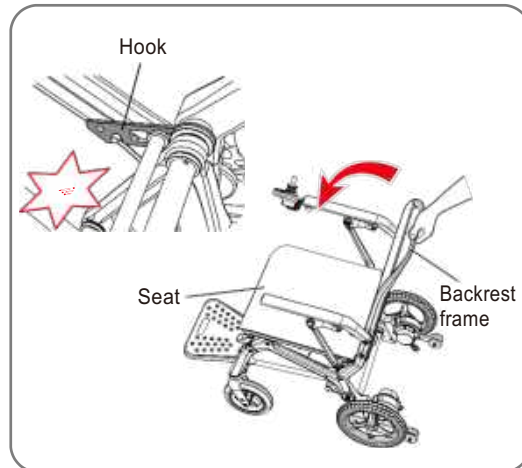

4.6.4 The wheelchair is fully opened.



4.INSTALLATION & ADJUSTMENT

4.7 FOLDING THE WHEELCHAIR

Attention:

Please remove the cushion, so that the wheelchair can be easily folded.

4.7.1 Step down the foldable lock handle with your right foot, and at the same time, hold the backrest frame with your right hand and push it forward until the hooks on both sides of the wheelchair are released as shown in the right diagram.

4.7.2 Once the hooks are released, raise your foot to release the foldable lock handle. Hold the backrest frame with your right hand and fold it downward toward the front and close it as shown in the right diagram.

4.7.3 When folded down and the "click" sound is heard, the lock piece blocks the screws and locks the wheelchair, so that it will not open automatically.

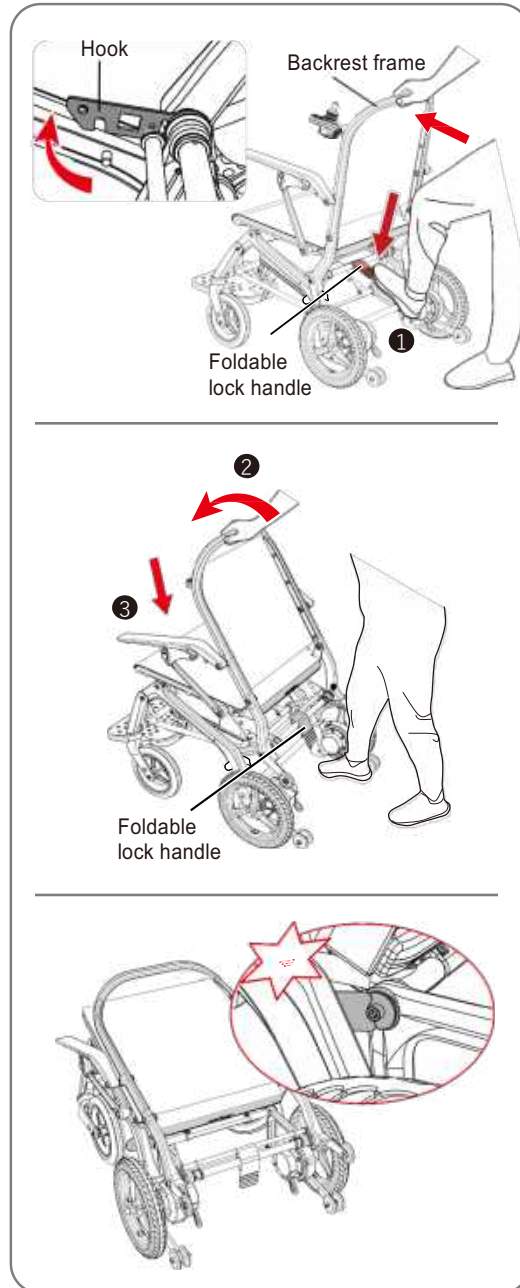

4. INSTALLATION & ADJUSTMENT

4.7.4 Once folded, flip the footrest inward again and put it together as shown in the right diagram.

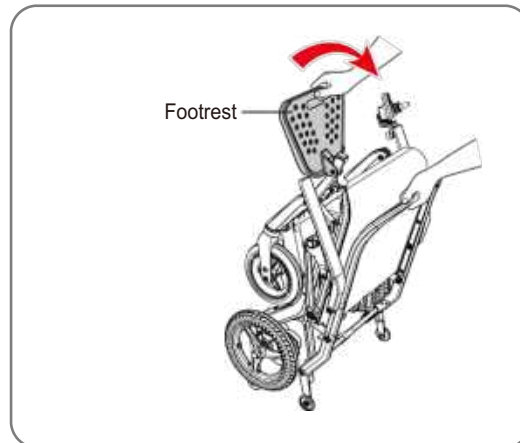

4.8 STANDING THE FOLDED WHEELCHAIR

After the wheelchair is folded, it can be stored vertically to save storage space.

WARNING

1. Before opening or folding the wheelchair, make sure there are no obstacles around the wheelchair.
2. Always make sure that your fingers are away from the mechanical joints of the folded wheelchair before opening or folding it to prevent hand pinching.
3. Do not sit on the seat or drive the wheelchair before the folded wheelchair is fully opened.
4. Make sure the wheelchair is fully opened before sitting on it or driving it.

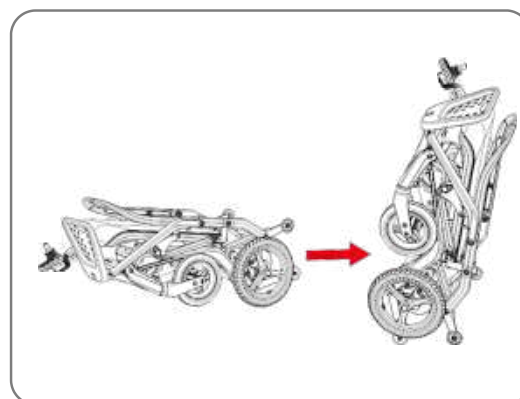

5. OPERATING INSTRUCTIONS

5. OPERATION – DRIVING THE POWERCHAIR

5.1 JOYSTICK



- | | |
|---------------------|----------------------|
| 1. Low Speed Button | 5. Horn Button |
| 2. On/off Button | 6. High Speed Button |
| 3. Battery Gauge | 7. Joystick lever |
| 4. Speed Indicator | |

- 1. LOW SPEED BUTTON:** Press to slow the speed.
- 2. ON/OFF Button:** Press once to turn on the powerchair and press once to turn-off the powerchair.
- 3. BATTERY GAUGE:** Indicates the battery voltage. Green is fully charged; Amber is half full and Red indicates that the battery needs charging.
- 4. SPEED INDICATOR:** Indicates the speed set by the 'Slow Speed' or 'Increase Speed' buttons.
- 5. HORN BUTTON:** This button activates a warning horn.
- 6. High SPEED BUTTON:** Press to increase the speed.
- 7. JOYSTICK LEVER:** The Joystick lever the direction in which you travel. Push forward to go forward, pull back to go backwards, left to go left and right to go right.

⊘ WARNING

It is forbidden to turn off the power during driving, as this operation will suddenly make the powerchair stop and possibly tip over.

Deleted: :

5. OPERATING INSTRUCTIONS

5.2 BEFORE SITTING ON YOUR POWERCHAIR

- Make sure the battery box switch is in the 'On' position.
- Make sure the Freewheel levers are in the 'Lock' position (see 4.2 Manual Freewheel lever).
- Make sure that the battery is fully charged.
- Secure the seat belt.
- Make sure the powerchair is fully opened and that the seat tubes are located correctly on the side brackets (see 4.6 Unfolding the powerchair).
- Make sure that the Joystick lever is turned off to prevent the powerchair from moving if accidental Joystick contact is made.

Deleted: -

5.3 STARTING

- Make sure you are seated safely.
- Make sure the footrests are fitted at the correct height for your feet.

5.4 STEERING

- The Joystick allows you to steer the powerchair. We recommend that you lower the speed setting to the lowest speed until you have gained experience and practice in maneuvering the powerchair.
- Make sure to maintain sufficient clearance when turning your powerchair so that the rear wheels will be clear of any obstacles.
- Show even greater caution when maneuvering and steering in reverse.

5.5 DRIVING ON INCLINES, SLOPES AND RAMPS

- When driving your powerchair, never descend or climb a gradient which is greater than recommended. See 4.0 Specifications.
- Always drive straight up or straight down an incline, ramp, slope etc.
- Never drive across (traverse) an incline, ramp etc, in any direction-Driving across an incline, ramp etc. could result in turning the powerchair over resulting in serious injury or death.
- Try and keep the powerchair moving when climbing or descending an incline. If you must stop, restart, and accelerate slowly and carefully.

WARNING! When driving on slopes the stopping distance of the powerchair can be significantly greater than on level ground.

Deleted: -s

6. BATTERY AND CHARGER

6.1 GENERAL INFORMATION & INSTRUCTIONS ON CHARGING

Your powerchair requires a lithium battery that is sealed and maintenance free. The battery is recharged by the supplied off-board charging system.

- Fully charge your powerchair's battery for at least 10 to 12 hours prior to using it for the first time. The new battery will be at its full capacity after having run through approx. 10-20 charging cycles (break-in period). This break-in period is necessary to fully activate the battery for maximum performance and longevity.
- Keep the battery fully charged to keep your powerchair running smoothly. Charge the battery daily after every discharge even after partly discharge. Depending on the level of discharge, it can take up to 12 hours until the battery is fully charged again.
- If the battery indicator has reached the red LED range, charge the battery for 12 hours minimum, ignoring the charge complete display!
- Even if the powerchair is unused for long period of time, the battery should have a regular charge to make sure that the battery remains fully charged.
- Do not cycle your battery at a low state of charge without regularly recharging it fully.
- Do not charge your battery under extreme temperatures. High temperatures above 40°C(104°F) are not recommended for charging as well as low temperatures below 10°C(50°F).
- Protect your charger from sources of heat such as heaters and direct sunlight. If the battery charger overheats, charging current will be reduced and the charging process delayed.

6. BATTERY AND CHARGER

6.2 CHARGING YOUR BATTERIES

- Make sure you read and understand the battery charger's user manual, if supplied, as well as the safety notes on the charger.
- Turn off the powerchair.
- Decide on which charging socket to use. You have 2 choices:
 1. Battery Box Socket (allows you to charge batteries 'off board' e.g. in your house) (Fig 6.2.1)
 2. Controller Charging Socket (saves you bending down to plug in charger) (Fig 6.2.2)

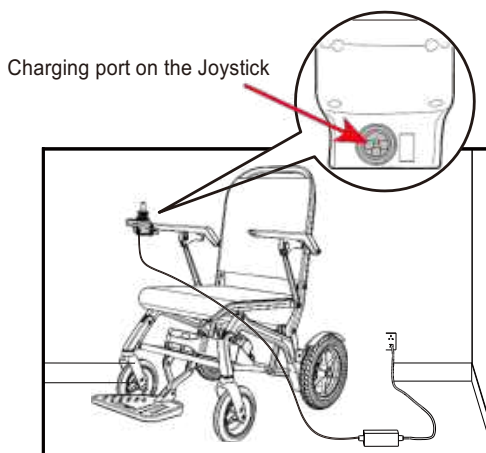
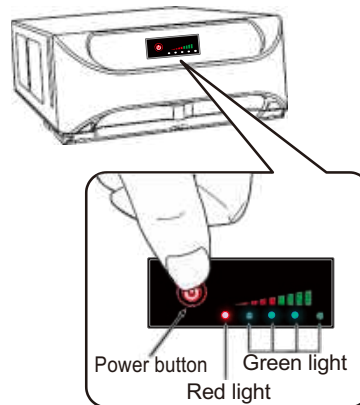

Fig 6.2.1



Note:

When you want to check the power, the button on the battery box should be "ON", then press the power button, the power indicator will be on and you can check the power.

Note: The indicator will be off automatically after 5 seconds.

1. Green indicator means the battery has power.
2. When the last four green indicators are off, it means that the power is low and the battery needs to be charged

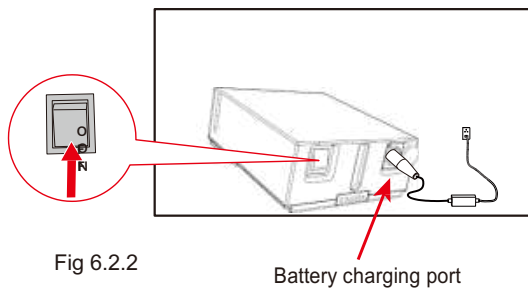

Fig 6.2.2

Note: The button on the battery box should be "ON" during the charging, i.e. charging with the power on.

6. BATTERY AND CHARGER

⚠ WARNING: Turn on the switch on the battery box prior to charging.

- Put the charger plug into the outlet point.
- Do not switch on the battery charger until all the plugs are in position.
- The LED light on the battery charger will show amber while charging.
- The LED light on the battery charger will show green when batteries are fully charged.
- Turn off the mains power to the charger before removing the charger plug from charging outlet.

⚠ WARNING! Risk of explosion and destruction of batteries if the wrong battery charger is used. Only ever use the battery charger supplied with your vehicle, or a charger that has been approved by Manufacturer.

⊘ WARNING! Do not use or store the battery near sources of heat such as a fire or heater.

⊘ WARNING! Never attempt to open or disassemble the charger. If the battery charger does not appear to be working correctly, contact your authorized provider.









⊘ WARNING! Do not use the battery if it gives off an odour, generates heat or appears abnormal in any way. If the battery is in use or being recharged, remove it from the device or charger immediately and discontinue use.

⚠ WARNING! Risk of electric shock and damage to the battery charger if it gets wet. Always protect the battery charger from water and always charge in a dry environment.

Deleted: I

Deleted: battery

6. BATTERY AND CHARGER

-  **WARNING!** Risk of short circuit and electric shock if the battery charger has been damaged. Never use the charger if it has been dropped or damaged.
-  **WARNING!** Risk of electric shock and damage to the batteries- Never attempt to recharge the batteries by attaching cables directly to the battery terminals.
-  **WARNING!** Risk of fire and electric shock if a damaged extension cable is used. Only ever use an extension cable if it is absolutely necessary. If you must use an extension cable, make sure it is in good condition.
-  **WARNING!** Risk of injury if using the powerchair during charging. Do not attempt to recharge the batteries and operate the powerchair at the same time. Do not sit in the powerchair while charging the batteries.
-  **WARNING!** Chargers are selected precisely for particular applications and are specifically matched to the type, size, and chemical formulation of specific batteries. For the safest and most efficient charging of your powerchair's batteries, we recommend using the charger supplied as original equipment with your product
-  **WARNING!** Never attempt to disassemble the battery from the battery box or refit the battery. Contact your authorized provider.
-  **WARNING!** If your battery charger has not been tested and approved for outdoor use, then do not expose it to adverse or extreme weather conditions. If the battery charger is exposed to adverse or extreme weather conditions, then it must be allowed to adjust to the difference in environmental conditions before use indoors. Refer to the manual supplied with the battery charger for more information.
-  **WARNING!** Never use or store the battery where it is exposed to high temperatures. Leaving the battery in a car on a hot day or in an area of direct sunlight such as window will reduce battery performance and shorten service life.

Deleted: especiallymatched

Deleted: -

7. DAILY CHECKING & MAINTENANCE

Protect your power chair by having it checked regularly. We strongly advise you to have your powerchair checked at least once a year by a qualified dealer, who will only use the correct spare parts. This periodic inspection will ensure you that the powerchair will function safely for years. There are a lot of things you can do yourself to keep your power-chair in optimal condition. If you regularly check the wheelchair and perform (small) maintenance, this will extend the lifetime and increase the ease of use.

Deleted: at

Deleted: perfectly

7.1 TYRES AND WHEELS

- Examine tyres periodically for wear and replace them as needed.
 - Make sure the wheels can move freely without touching anything.
- The front wheel and fork should move freely to ensure a smooth ride.

7.2 MOTOR

- Is there any abnormal noise from the motor? Does the electromagnetic brake work properly?

7.3 CROSS FRAME

- Check that the cross frame of the wheelchair is in good condition. Make sure the wheelchair is easy to fold and un-fold.

7.4 BATTERY GAUGE

- Does the gauge move to green when switched 'ON'?
- Is the remaining power enough for you trip?

7.5 HORN BUTTON

- Is it working correctly?

7.6 UPHOLSTERY

- Check the textile for holes, cracks and worn spots.
- Check the upholstery-mounting grommets to make sure that they are all correctly aligned and secure.

7.7 CLEANING

- Clean the upholstery, chassis, plastic components, and non-electric parts on the powerchair regularly with a either a dry or moist cloth.
- Do not use water, oil or other chemical solutions to clean your powerchair. Be sure NOT to spray the powerchair with water as this can damage the electronic components. Please clean the powerchair by wiping it with either a dry or moist cloth.
- Please take the powerchair to an authorized dealer for repairs and adjustments. Improper adjustments could lead to accidents and powerchair malfunction.

7.8 UNIQUE IDENTIFICATION NUMBER

- Your powerchair has a unique identification number which is located at several different locations on the chassis and the battery box. This unique number will enable your authorized supplier to confirm with manufacturer if necessary, the age of your powerchair and when it was purchased.

7.9 END OF USE

 The symbol means that your product should be disposed of separately from household waste according local laws and regulations. At the end of the wheelchair life, take it to the designated recycling place. Sorting and recycling will help conserve natural resources, and ensure it is recycled in an environmentally friendly way.

Deleted: the

Deleted: ,

Recycling of each part should be handled by a designated authorized recycling organization in accordance with local laws and regulations. As for plastic parts, frame and pipe parts, they can be handed over to professional recycling units for disposal after the end of use.

8 WARRANTY

WARRANTY POLICY:

LIMITED WARRANTY. IMPORTANT NOTICE-TO ENSURE THIS WARRANTY IS VALIDATED IT HAS TO BE COMPLETED AND RETURNED TO DEALER WITHIN 14 DAYS OF PURCHASE

8.1 ONE-YEAR LIMITED WARRANTY:

For one (1) year from the date of delivery, we will replace at our discretion to the original purchaser, free of charge, any part or electronic component found upon examination by an authorized representative of Manufacturer to be faulty.

- 1.Main Frame
- 2.Electronic controllers
- 3.Motor
- 4.Electronic magnetic brake
- 5.Charger
- 6.Any other electrical subassembly

Deleted: megnatic

NOTE: If there is an increase in the noise level from the motor/transaxle, the warranty does not apply. An increase in operational noise level usually occurs due to excessive strain on the powerchair.

8.2 BATTERIES

Batteries are covered by a six (6) month warranty from the original manufacture and a further six (6) month warranty.

Note: Gradual deterioration in performance due to batteries being left in a discharged state, left in cold conditions for long periods of time or worn out through heavy use is not covered.

8.3 WARRANTY EXCLUSIONS

1. Plastic parts footplate covers.
3. Tyres and Anti-tip Wheels.
4. Upholstery and seating.
5. Fuses.
6. Repairs and/or modifications made to any part of the powerchair without specific and prior consent from Manufacturer.
7. Circumstances beyond the control of manufacturer.

Exclusions also include components with damage caused by:

- 1.Contamination (rain, etc.).
- 2.Abuse, misuse, accident, or negligence.
- 3.Commercial use, or use other than normal.
- 4.Improper operation, maintenance, or storage.

NOTE: Gradual deterioration in performance because the battery has been left in a discharged state, left in cold conditions for an extended period of time, or worn out through heavy use is not covered by the warranty.

8.4 SERVICE CHECKS AND WARRANTY SERVICE

This warranty is extended only to the original purchaser. Your original receipt will be necessary as proof of purchase before any warranty performances are rendered.

This warranty only covers failures due to defects in materials or workmanship which occur during normal use and does not cover damage that occurs in shipment or failures which are caused by products not supplied by Manufacturer or failures resulting from accident, misuse, abuse, neglect, mishandling, misapplication, alteration, modification, commercial use or by anyone other than an authorized dealer, or damage that is attributable to the acts of God.

The manufacturer reserves the right to alter without notice, any weights, measurements or other technical data shown in this manual. All figures, measurements and capacities shown in this manual are approximate and do not constitute specifications.

Important

This warranty is void if the original powerchair serial number tag is removed or altered.

To validate the warranty this form must be filled in online (where applicable) or posted to Manufacturer.

8 WARRANTY

8.5 NOTICES TO CONSUMER

There are no other express warranties. To the extent permitted by law, any implied warranty (including a warranty of merchantability or fitness for a particular purpose) is limited to:

1. One (1) year from the day of purchase.
- 2.. Repair or replacement of the defective part only.

8.6 MAINTENANCE RECORDS

Deleted: MAINTENENCE

<u>Maintenance</u> records			
Date	Issue	Cause	Remark

Deleted: Maintenece

Deleted: d

Name:	
Address:	Telephone:
Product name:	Barcode:
Purchasing date:	
Warranty period: (Except for wearing parts) , Others show in the instruction manual.	

Note: Please go to the dealer for warranty registration within one month, this card will be valid with the seal of the dealer or the manufacturer, and the warranty will be carried out with this card.

9 BASIC TROUBLESHOOTING

9.1 FLASH CODE

TROUBLE SHOOTING

Fault Codes

If a system trip occurs, you can find out what has happened by counting the number of flashes on the Joystick Module BDI.

Below is a list of self-help actions. Try to use this list before you contact your service agent. Go to the number in the list which matches the number of flashes on the BDI and follow the instructions.

If the problem persists after you made the checks described, contact your service agent.

FLASH CODE	FAULT	EFFECT ON THE POWERCHAIR	SOLUTION
1	Battery charge is too low or there is a bad connection.	Powerchair continues to drive.	<ul style="list-style-type: none"> • Charge batteries. • Check all battery wiring connections. • Contact your service agent.
2	Bad connection to left hand motor.	Powerchair stops driving.	<ul style="list-style-type: none"> • Check all connections between the motor and controller. • Motor may be faulty and need replacing. • Contact your service agent.
3	Faulty left hand motor wiring or a stall condition has been detected.	Powerchair stops driving.	<ul style="list-style-type: none"> • Check all connections between the motor and controller. • Motor may be faulty and need replacing. • Contact your service agent.
4	Bad connection to right hand motor.	Powerchair stops driving.	<ul style="list-style-type: none"> • Check all connections between the motor and controller. • Motor may be faulty and need replacing. • Contact your service agent.
5	Faulty right hand motor wiring or a stall condition has been detected.	Powerchair stops driving.	<ul style="list-style-type: none"> • Check all connections between the motor and controller. • Motor may be faulty and need replacing. • Contact your service agent.
7	A Joystick fault is indicated.	Powerchair stops driving.	<ul style="list-style-type: none"> • Make sure the Joystick is in the centre position before switching on the controller. • Contact your service agent.
7+ 'S'	A communication fault is indicated.	Powerchair stops driving.	<ul style="list-style-type: none"> • Make sure the Joystick cable is securely connected and not damaged. • Contact your service agent.
8	Controller error.	Powerchair stops driving.	<ul style="list-style-type: none"> • Check all wiring connections including main battery connections. • The controller needs replacing. • Contact your service agent.
9	Brake error.	Powerchair stops driving.	<ul style="list-style-type: none"> • The electronic brakes have a bad connection or fault. • Check the brakes and motor connections • Also check the controller connections. • Contact your service agent.
10	Excessive Voltage	Powerchair stops driving.	<ul style="list-style-type: none"> • This is usually caused by poor battery connections. • Check the battery connections.

10 TRANSPORTATION AND STORAGE

10.1 TRANSPORTATION AND STORAGE

- a) Ambient temperature range: -25°C — 50°C / -13°F — 122°F ;
- b) Relative humidity: $\leq 80\%$
- c) Atmospheric pressure range: 86kPa ~ 106kPa ;
- d) Can be transported in general transportation.

10.2 Operation

- a) Ambient temperature range: -5°C — 40°C / 23°F - 104°F ;
- b) Relative humidity: $\leq 85\%$
- c) Atmospheric pressure range: 86kPa ~ 106kPa ;

Manufacturer information:

Kunshan Hi-Fortune Health Products Co., Ltd
No.625 Juxiang Road zhangpu town ,
Kunshan City Jiangsu Province, China
TEL:+86 512 55195100.
FAX: +86 512 55199300
www.hi-fortune.net

UK Responsible Person/Northern Ireland Authorised Representative Information:

SUNGO Certification Company Limited
3rd Floor, 70 Gracechurch Street
EC3V 0HR
London, England,
United Kingdom



Date: 2024-01-11 Version: V.01