

---

# MOTIVATION MULTISPORT / MULTISPORT JUNIOR WHEELCHAIR

## ASSEMBLY MANUAL



# Contents

Bumper assembly	1
Backrest assembly and height adjustment	2
Adult footrest adjustment	5
Junior footrest adjustment	6
Rear Anti Tip wheel adjustment	7
Rear wheel assembly	8
Care and maintenance Instructions	9



# Bumper Assembly

- 2 x 
- 2 x 
- 4 x 

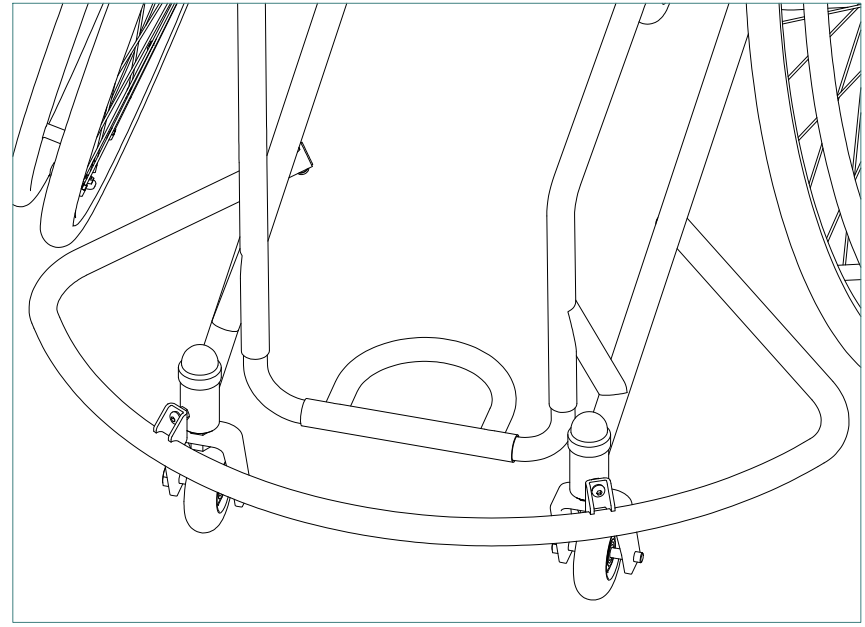
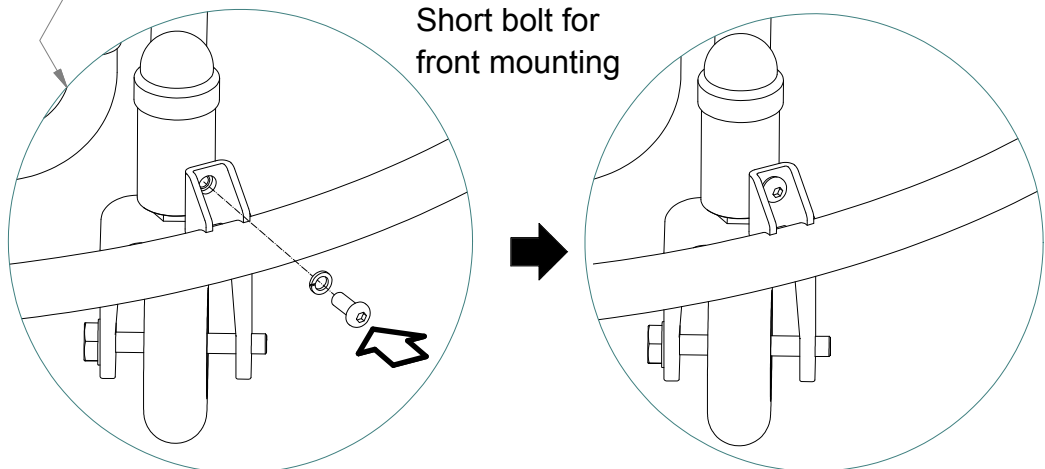
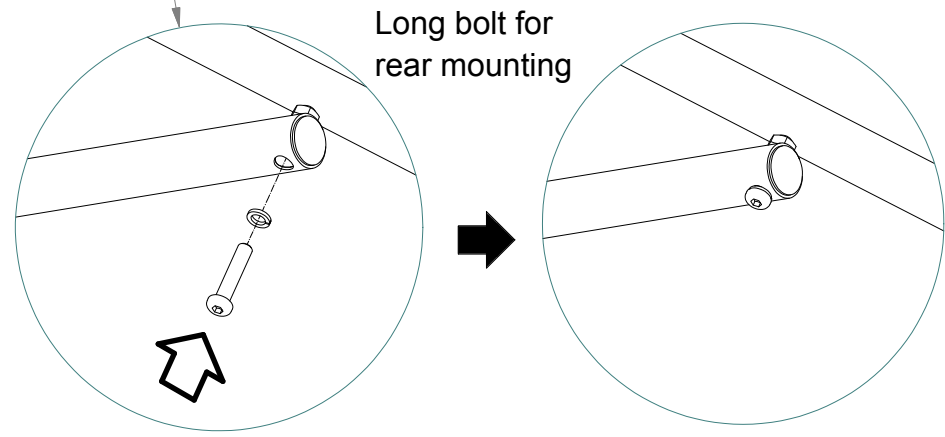
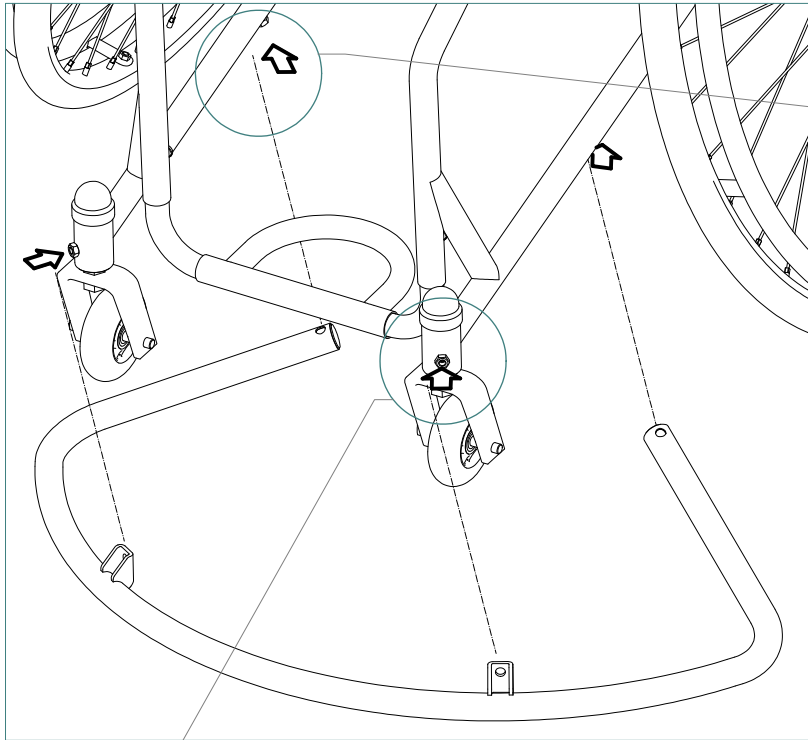

Assembly complete

# Backrest assembly and height adjustment

2 x  
(1 : 2)

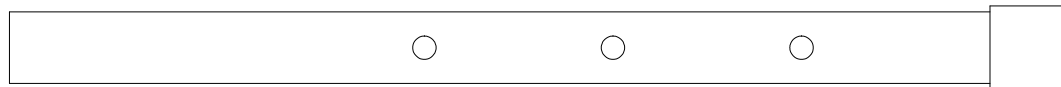

2 x

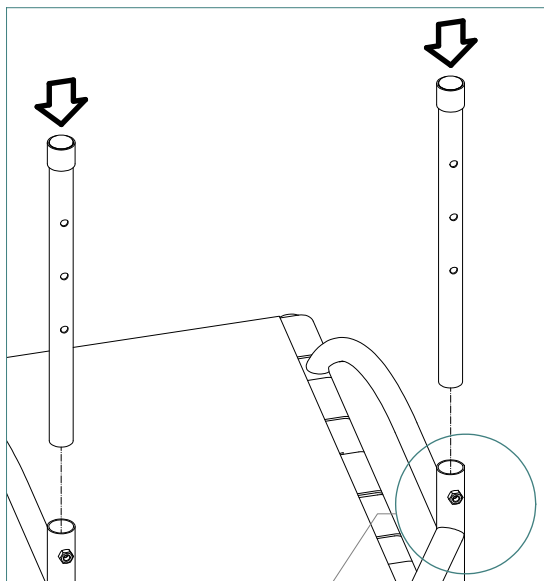

3 height options

Low

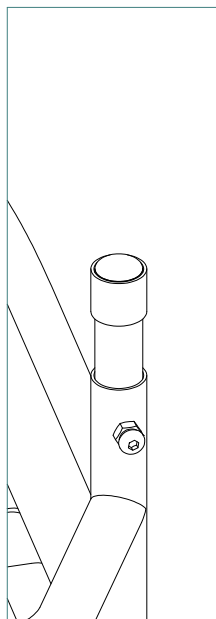

Medium

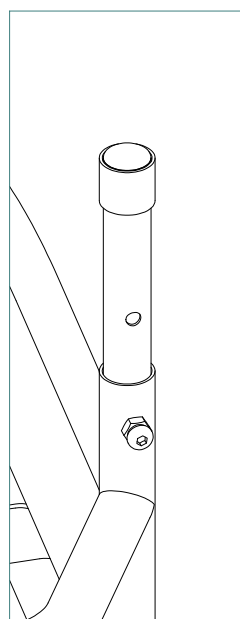

High

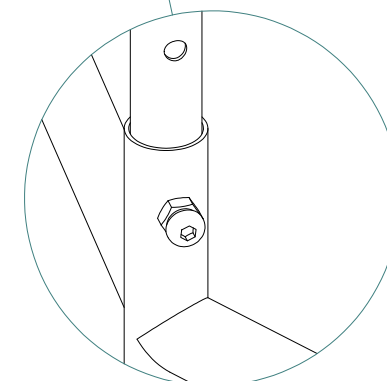
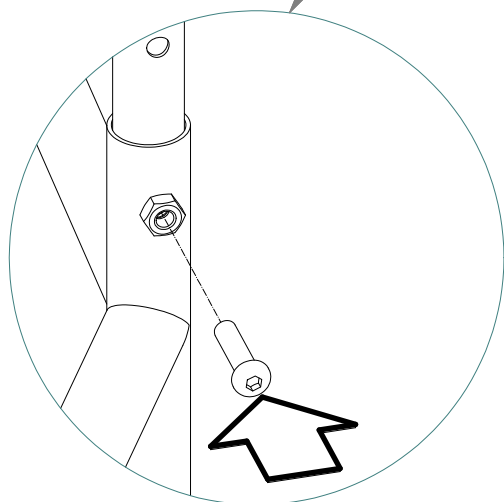
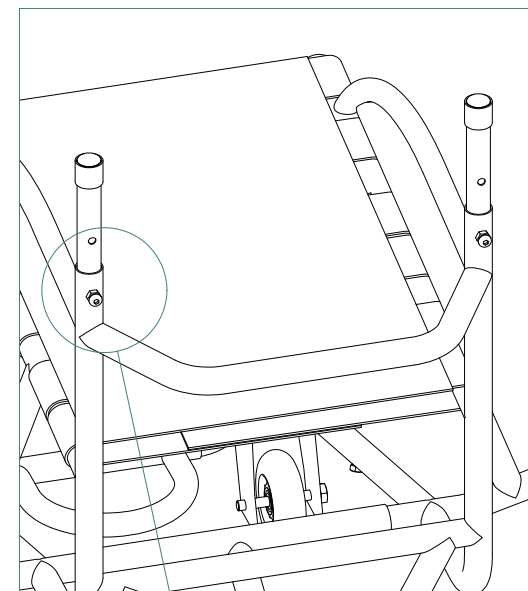
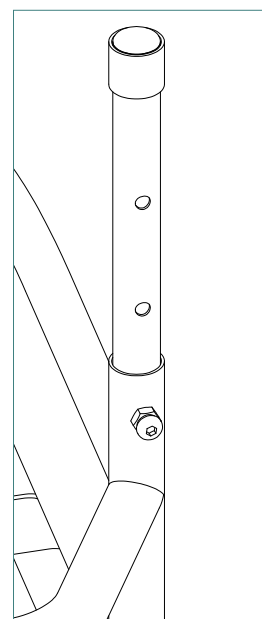

# Backrest assembly and height adjustment

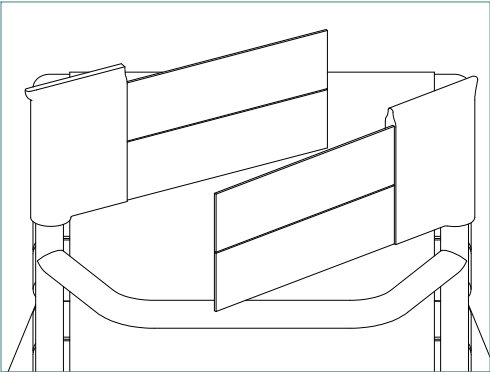

1. Adjust the tension of the backrest using the velcro straps

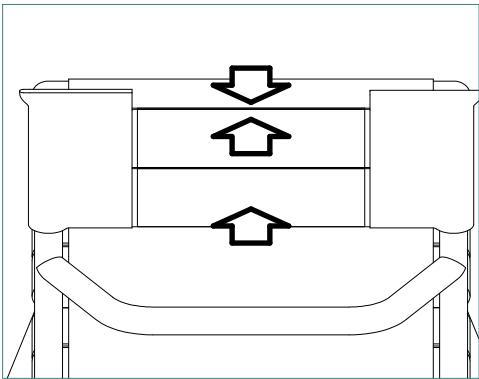

2. Press the straps together

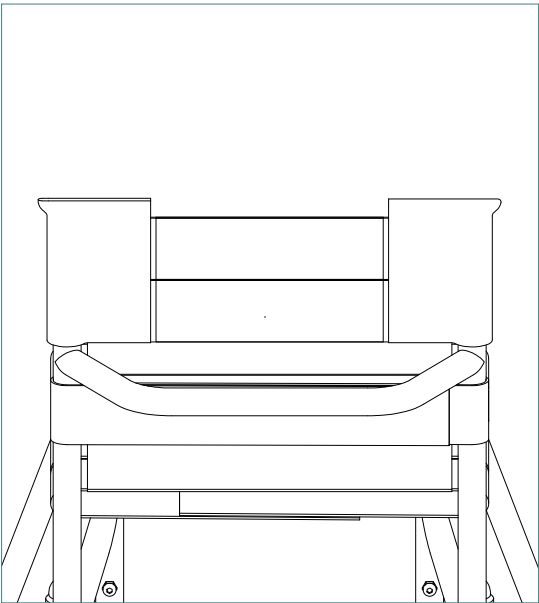
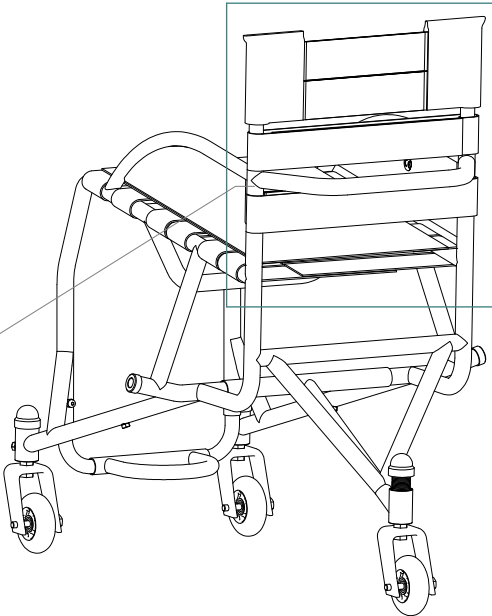

Low Backrest:  
Place a single strap below the backrest cross tube

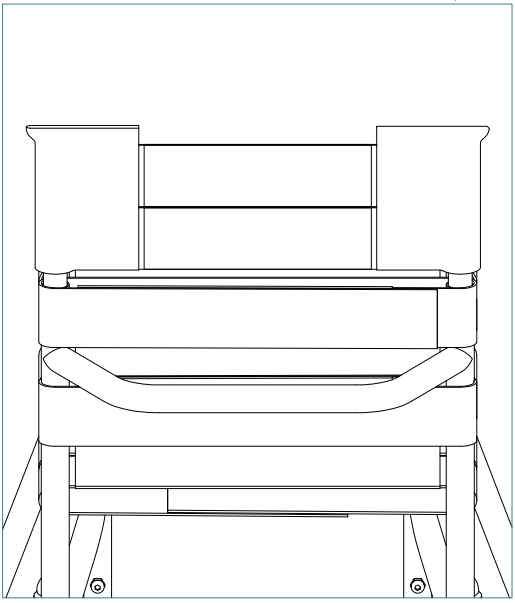

Medium backrest:  
Place a single strap above and below the backrest cross tube

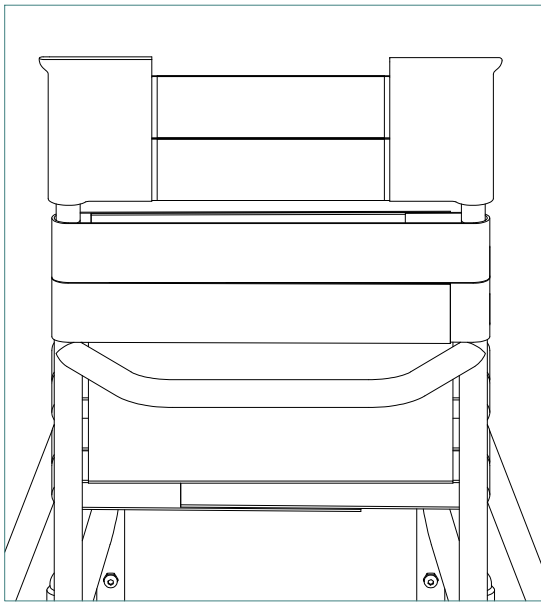

High Backrest:  
Place two single straps above the backrest cross tube

## Backrest assembly and height adjustment

1

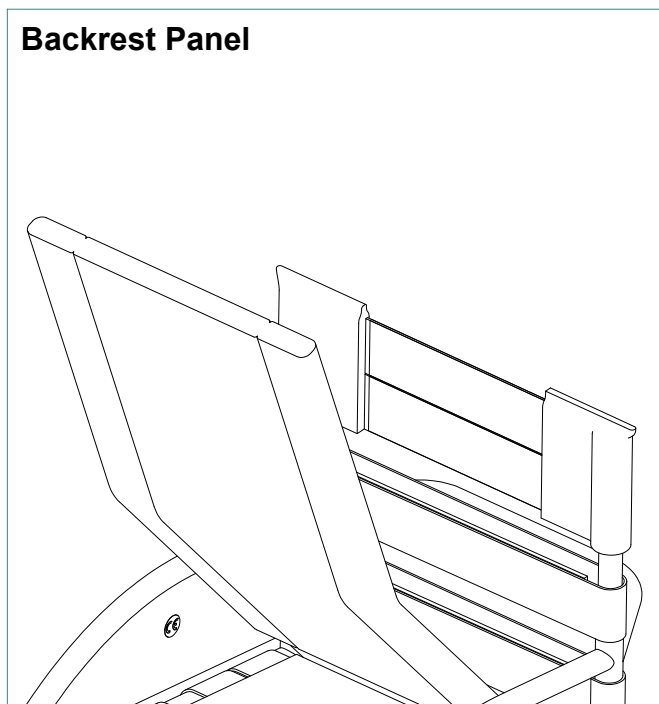

1. Fix the bottom of the Backrest Panel, down to the seat, using the velcro strips

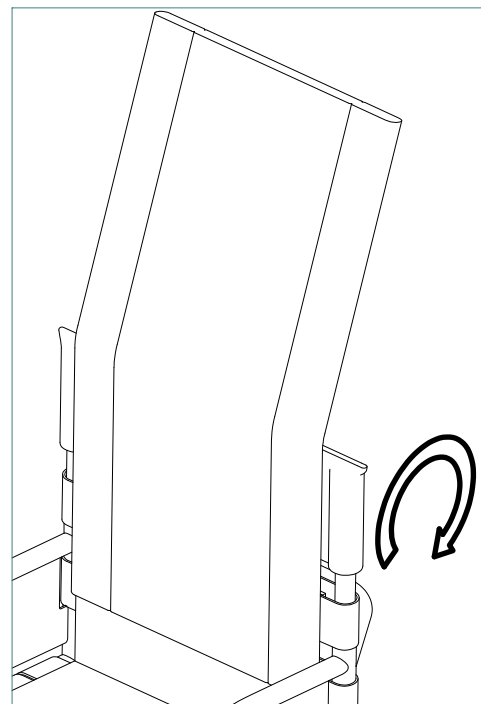

2. Fix the Backrest panel, to the front of the backrest straps, using the velcro strips

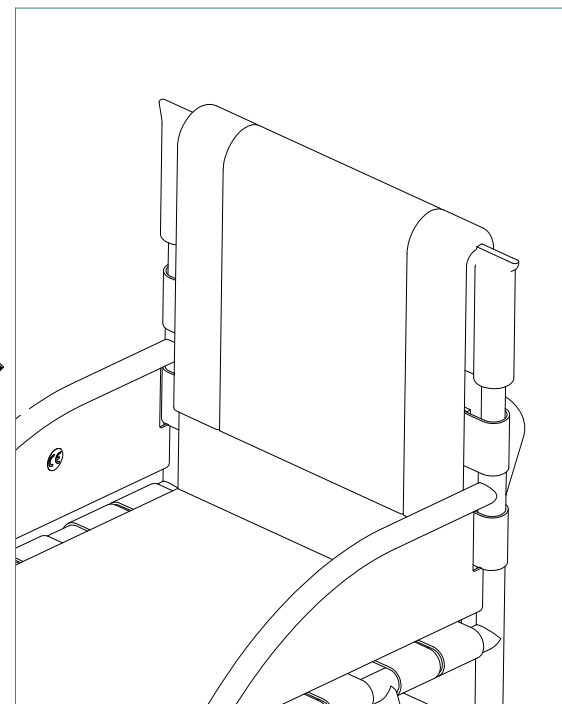

3. Fold the Backrest Panel over the top of the backrest straps and fix to the back of the straps using the velcro strips

2

### Rear Padding

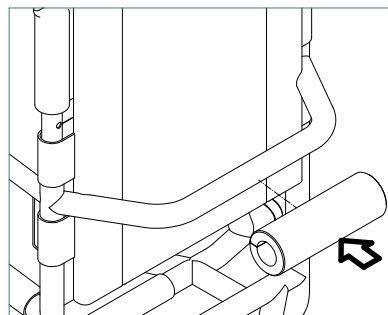
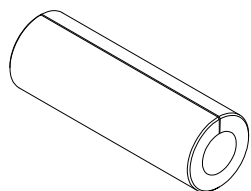

1. Push the Rear Padding over the cross tube

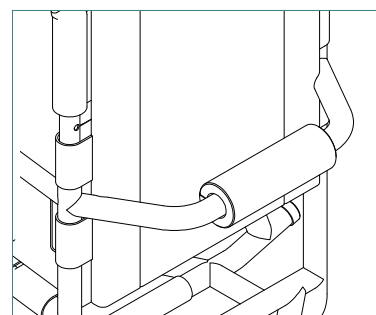

2. Place Rear Padding in the centre of the cross tube

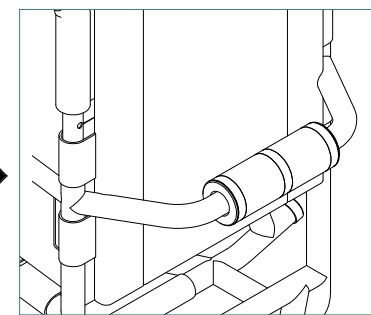

3. Use strong tape to hold the Rear Padding in Place

# Adult Footrest Adjustment

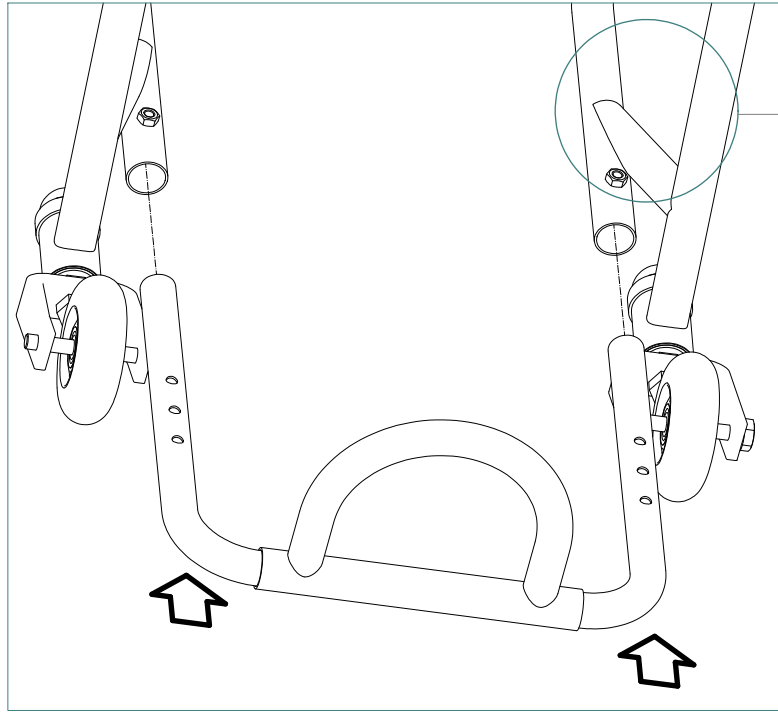

1 x  
(1 : 6)

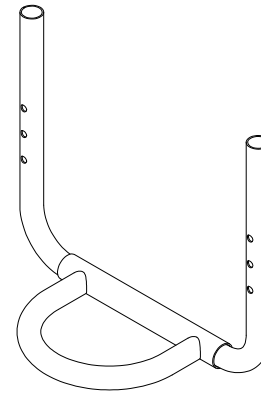

2 x

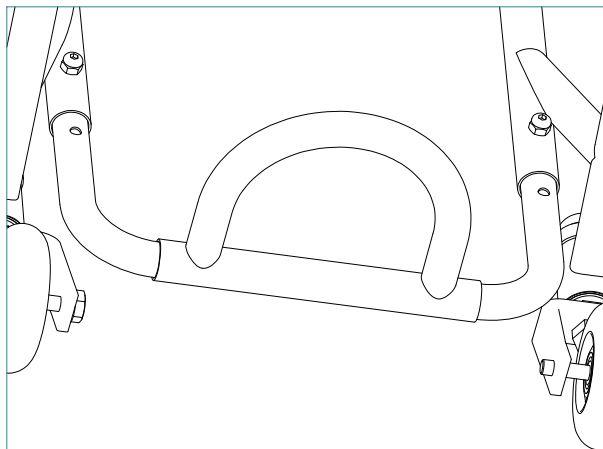
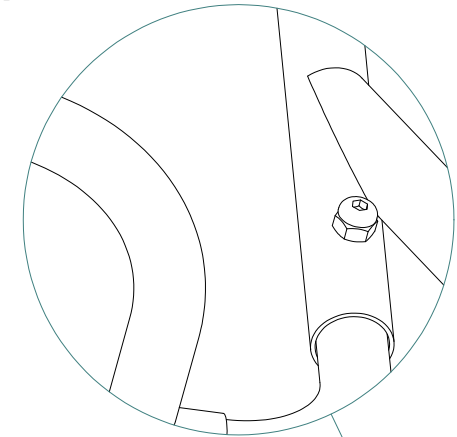
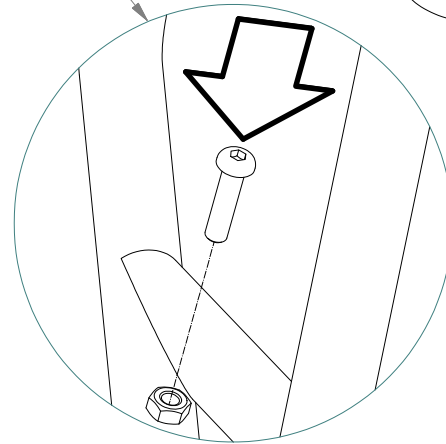

Low footrest position

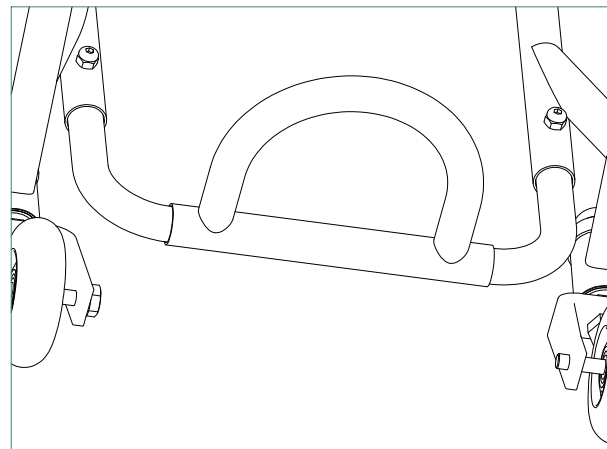

Medium footrest position

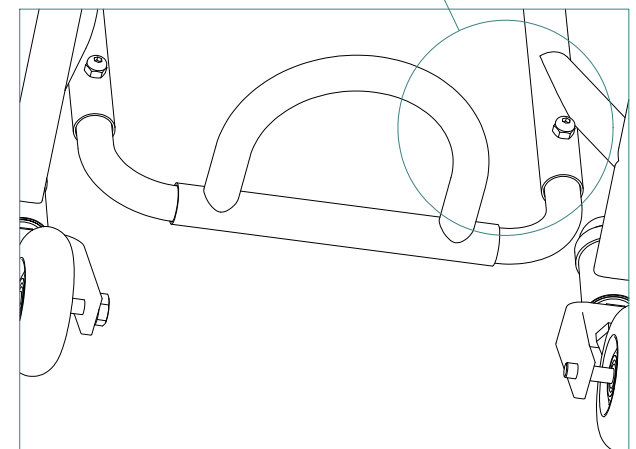

High footrest position

## Junior Footrest Adjustment

2 x 

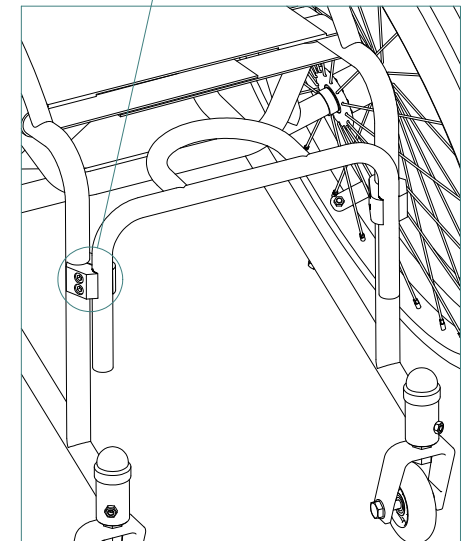
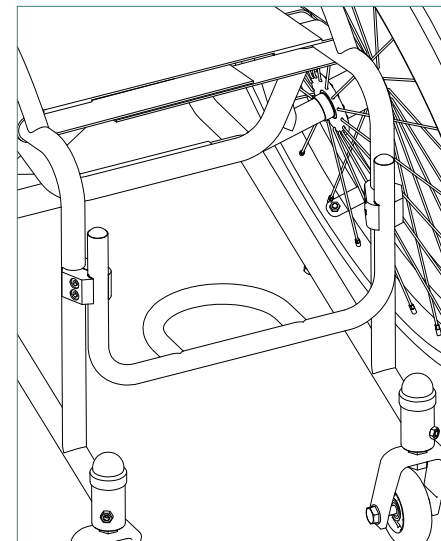
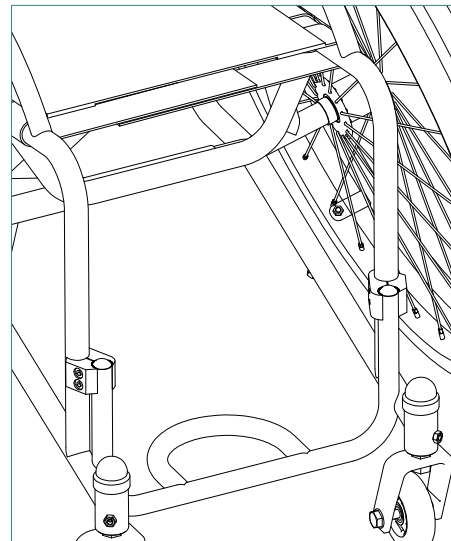
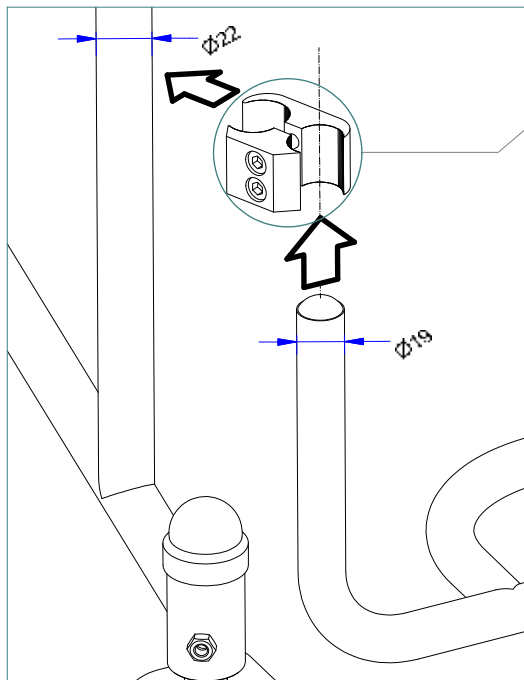
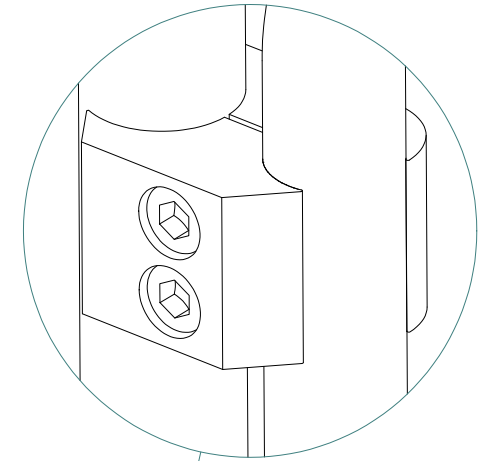
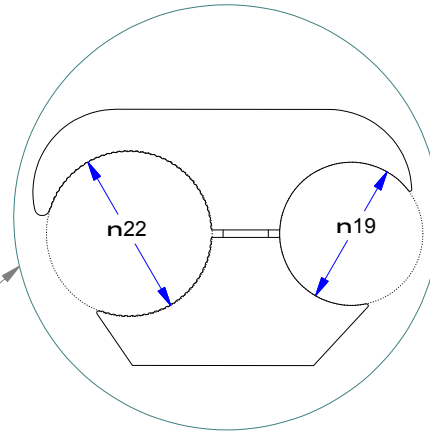
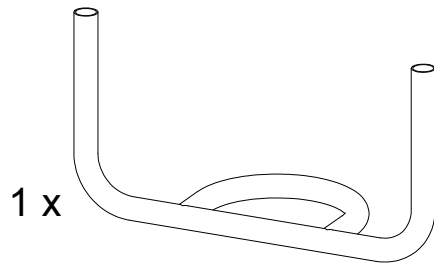

Mount the footrest to the frame using the two tube clamps provided, making sure to clamp the correct tube into the correct side of the clamp

Using the clamps to provide a low footrest position

Using the clamps to provide a medium footrest position

Using the clamps to provide a high footrest position



## Rear Anti Tip Wheel Adjustment

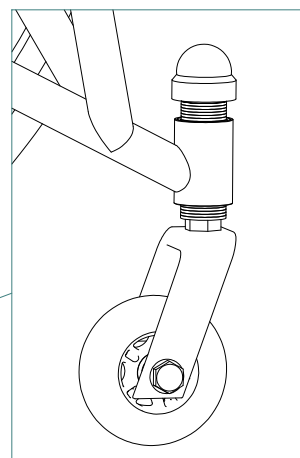
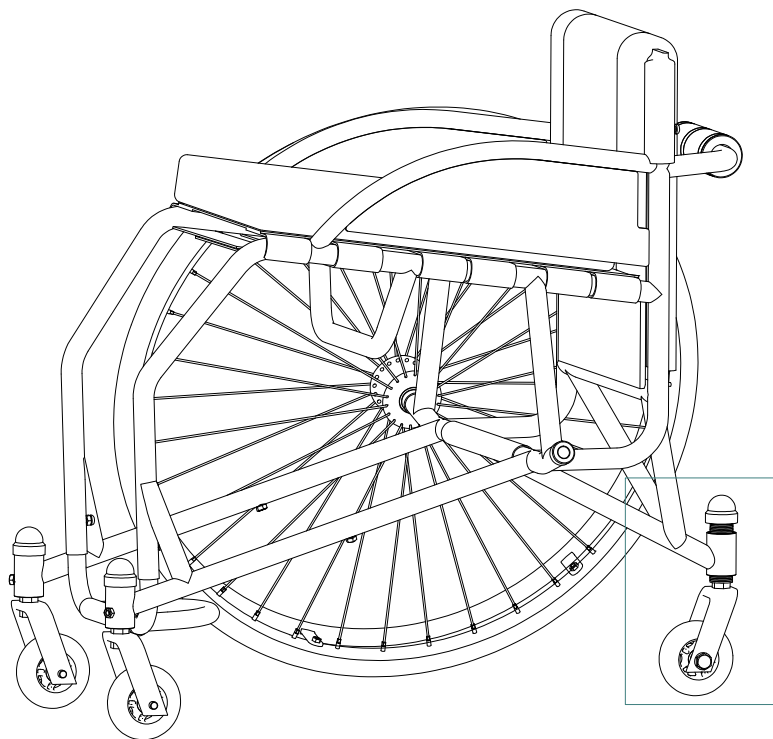

Medium height:  
washers are placed  
above and below the  
castor barrel

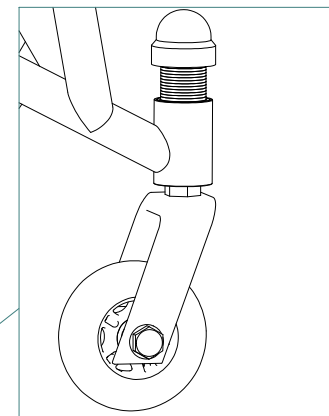

High height:  
washers are placed  
above the castor barrel

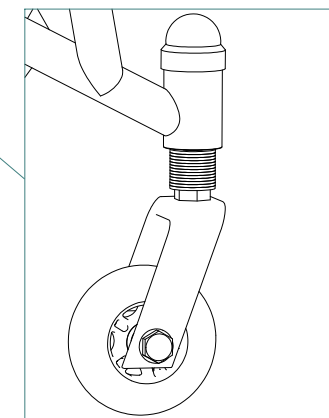

Low height:  
washers are placed  
below the castor barrel

## Rear Wheel Assembly

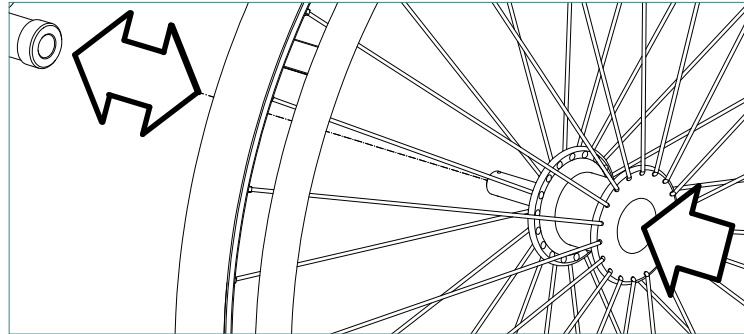

1. Push the button on the quick release axle to disengage the lock mechanism

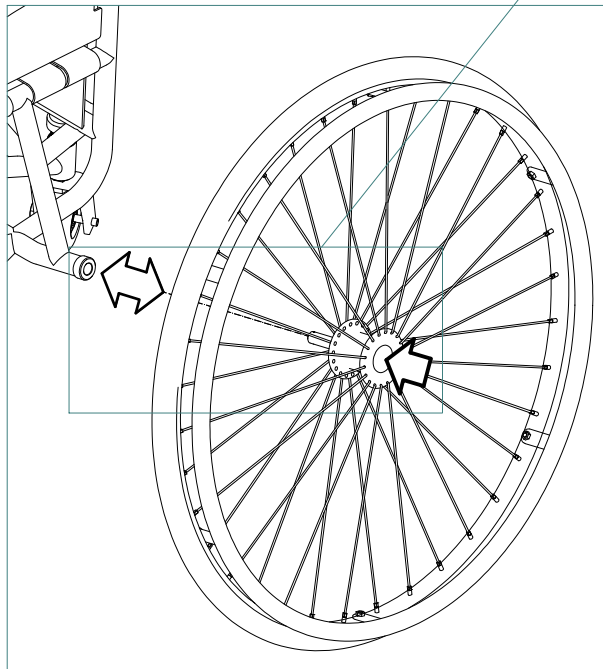

2. Slide the quick release axle into the axle mounting on the frame.  
Let go of the button to lock the axle into the frame

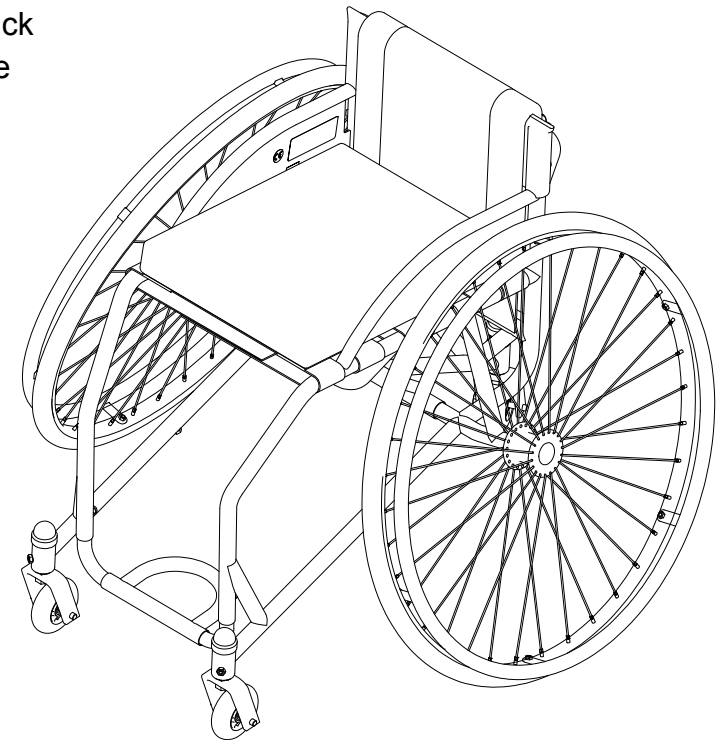

## Care and Maintenance Instructions



### 1. Cushion and upholstery

- Check condition at least once a month
- Look for ripped fabric or seams and worn out foam
- Keep the cover and seat upholstery tight at all times
- Wash cushion cover and upholstery whenever it is unclean or if it comes in contact with urine
- Dry the cushion and upholstery fully before re-fitting to the wheelchair
- Never expose the cushion to direct sunlight, even when drying

### 2. Castor and fifth wheel

- If the castor wheels or fifth wheel do not run smoothly, the bearings may need changing

### 3. Rear wheels

- If the wheels do not run smoothly, the bearings may need changing
- Check tyres are hard daily and pump tyres when soft to ensure tyres last longer
- Fix any punctures immediately
- Check spokes are tight at least once a month
- Check the rear wheel quick-release axles are secure at least once a month

### 4. Footrest

- Never put hand on the footrest during transfers
- Never stand or carry loads on the footrest castor and fifth wheel

### 5. Protective bumper

- At regularly intervals check that all four bolts are tight